

The machine is only to be installed in locations where its use and maintenance is restricted to trained personnel.

This machine is designed for indoor use only.

**DO NOT** install the machine in an area where a water jet could be used. Failure to follow this instruction may result in serious electrical shock.

### AIR COOLING UNITS

The model 6378 ice cream machine is air cooling unit. It requires a minimum of 6" (152 mm) of clearance around all sides of the machine and 12" (305mm) on top to allow for adequate air flow across the condenser. Failure to allow adequate clearance can reduce the refrigeration capacity of the machine and possibly cause permanent damage to the compressor.

### ELECTRICAL HOOK-UP INSTALLATION FOR 380 VOLT/ 50HERTZ/ 3 PHASE, SUPPLIED WITH CORD

Check the data label, located in the rear panel, for electrical specifications. The power supply must be connected through the circuit breaker.

This equipment is supplied with a 5-wire, 3 Phase wires (No. U, V, W), 1 Neutral wire (No. N, Blue color) and 1 Earth wire (Yellow-Green Color) for connection to a three phase, 380 Volt, 50 Hertz, branch circuit supply. The neutral wire must be properly connected. This unit must be properly grounded. The thickness of cord is 2.5mm<sup>2</sup>; therefore the fixed wire must also be over 2.5mm<sup>2</sup>.

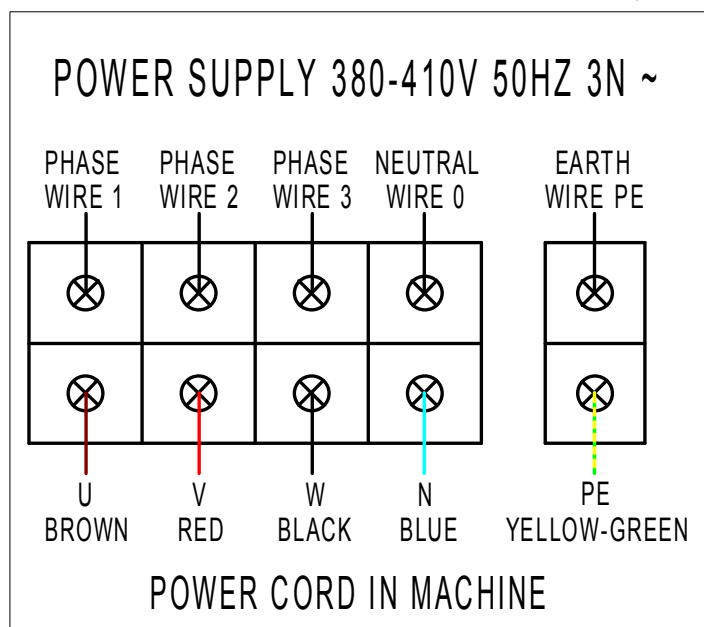

**CAUTION: Be Sure The Circuit Breaker Is OFF When Replacing Any Parts.**

Beater rotation must be clockwise as viewed looking into the freezing cylinder. To reverse the direction rotation, when wrong, it is necessary to interchange two of the three leads coming from the circuit breaker. This procedure should be performed by a trained service technician.

In all other areas of the world, equipment should be installed in accordance with the existing local codes. Please contact your local authorities.

**CAUTION: THIS EQUIPMENT MUST BE PROPERLY GROUNDED! FAILURE TO DO SO CAN RESULT IN SEVERE PERSONAL INJURY FROM ELECTRICAL SHOCK!**

**CAUTION: BE SURE THE MACHINE IS ELECTRICALLY DISCONNECTED, WHEN REPLACING ANY PARTS.**

**SPECIFICATIONS****Model 6378****FLOOR MODEL, PRESSURE PUMP MACHINE****Dimensions:**

MachinePacking

60cm width, 70cm depth, 154cm height 70cm width, 800cm depth, 175cm height

**Weight**

Machine: 270kg      Packing:290kg

**Electrical:**

Voltage AC: 380V,50 Hertz, 3 Phase Total Run Amps: 20 Amps

RATED CURRENT: 20 A

Main Compressor: Two, 7400 BTU/hr., R404a;  
(BTU may vary depending on compressor used.)

Drive Motors: 2X1.0 HP

**Hopper**

Two hopper, 15.0 liters, refrigerated and insulated.

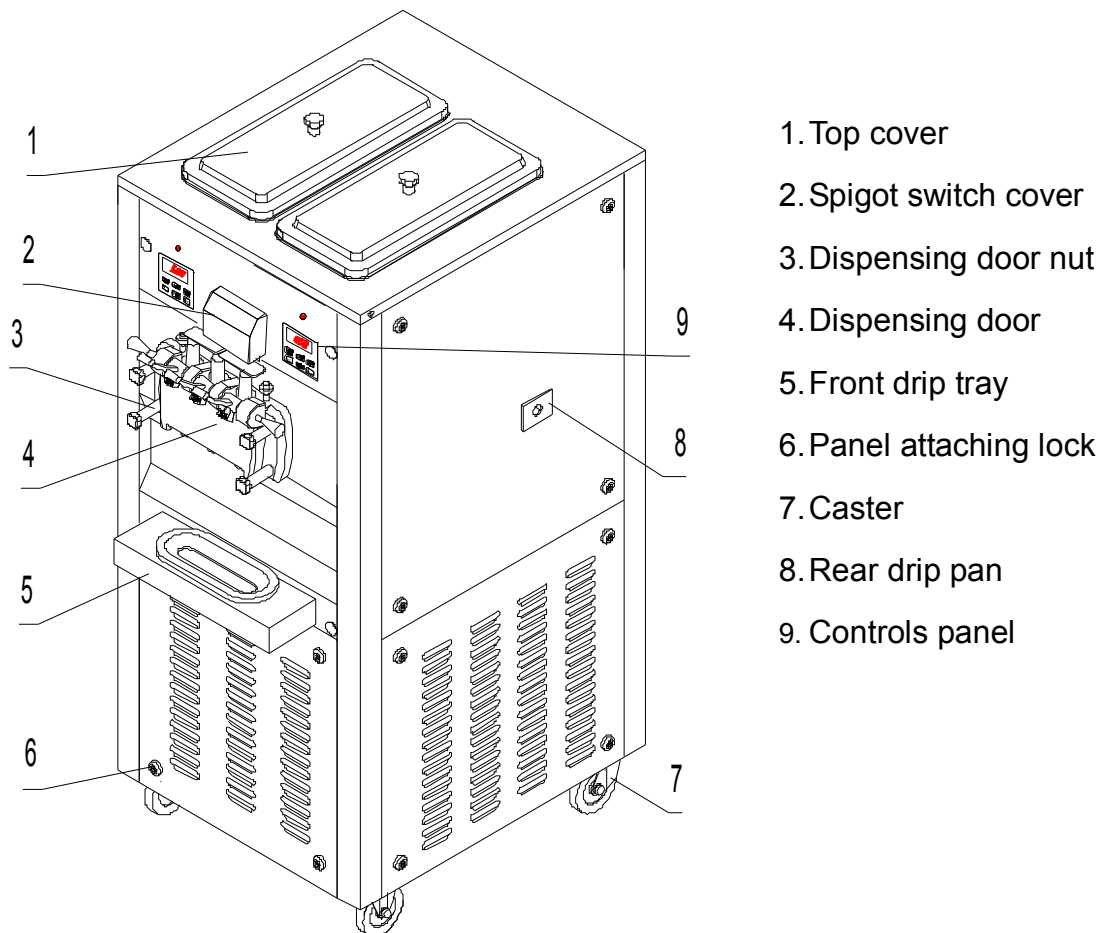
**Machine view**

The machine you have purchased has been carefully engineered and manufactured to give you dependable operation. The SPACEMAN Model 6378 is highly sophisticated pieces of equipment, and when properly operated and cared for, will produce a consistent quality product. Like all mechanical products, they will require cleaning and maintenance. A minimum amount of care and attention is necessary if the operating procedures outlined in this manual are followed closely.

This Operator's Manual should be read before operating or performing any maintenance on your equipment.

Your machine will NOT eventually compensate and correct for any errors during the set-up or filling operations. Thus, the initial assembly and priming procedures are of extreme importance. It is strongly recommended that all personnel responsible for the equipment's operation study these procedures together in order to be properly trained and to make sure that no misunderstandings exist.

In the event you should require technical assistance, please contact your local authorized SPACEMAN Distributor.

If the crossed out wheeled bin symbol is affixed to this product, it signifies that this product is compliant with the EU Directive as well as other similar legislation in effect after August 13, 2005. Therefore, it must be collected separately after its use is completed, and cannot be disposed as unsorted municipal waste.

The user is responsible for returning the product to the appropriate collection facility, as specified by your local code.

For additional information regarding applicable local laws, please contact the municipal facility and/or local distributor.

### **MIX INFORMATION**

The Hygeian ice cream powder is required to be used for frozen production. Mix can vary considerably from one manufacturer to another. Differences in the type of ingredients, quality, and quantity all have a different bearing on the finished frozen product. A change in machine performance that cannot be explained by a technical problem may be related to mix. Mix does not improve with age. Old mix or mix that has been stored at too high a temperature can result in a finished product that is less than satisfactory from the appearance and taste standpoint.

We recommend to always use high quality mix for ice cream production in order to satisfy your customers, even the most hard-to-please ones. Any saving made to the prejudice of quality will surely turn into a loss much bigger than the saving itself.

Always maintain at least 2cm of mix in the hopper. The maximum of mix in the hopper is not more over small hole of pump. See Figure 6-25 on page 28.

We are concerned about the safety of the operator when he or she comes in contact with the machine and its parts. We have gone to extreme efforts to design and manufacture built-in safety features to protect both you and service technician.

**IMPORTANT- Failure to adhere to the following safety precautions may result in severe personal injury. Failure to comply with these warnings may damage the machine and its components. Component damage will result in part replacement expense and service repair expense.**

**TO OPERATE SAFELY:**

**DO NOT** operate the machine without reading this operator's manual. Failure to follow this instruction may result in equipment damage, poor machine performance, health hazards, or personal injury.

**DO NOT** operate the machine unless it is properly grounded.

**DO NOT** attempt any repairs unless the main power supply to the machine has been disconnected.

**DO NOT** operate the machine with larger fuses than specified on the machine data label.

**Failure** to follow these instructions may result in electrocution or damage to the machine

**DO NOT** use a water jet to clean or rinse the machine. Failure to follow this instruction may result in serious electrical shock.

**DO NOT** allow untrained personnel to operate this machine.

**DO NOT** operate the machine unless all service panels and access doors are restrained with screws.

**DO NOT** remove the door, beater and blades, or drive shaft unless all control switches are in the OFF position.

**DO NOT** put objects or fingers in door spout.

**Failure** to follow these instructions may result in contaminated product or severe personal injury to fingers or hands from hazardous moving parts.

**USE EXTREME CAUTION** When removing the beater assembly. The scraper blades are very sharp and may cause injury.

This machine must be placed on a level surface. Failure to comply may result in personal injury or equipment damage.

**DO NOT** obstruct air intake and discharge openings: 6" (152 mm) minimum air space on sides and rear, and 12" (305 mm) minimum on top.

**Failure** to follow this instruction may cause poor freezer performance and damage to the machine.

This machine is designed to operate indoors, under normal ambient temperatures of 70°~75°F (21°~24°C). The machine has successfully performed in high ambient temperatures of 104°F (40°C) at reduced capacities.

**CAUTION: Failure to install the machine within recommended limits will result in poor performance of this system, premature component failure and cancellation of the warranty.**

Installations of machine involves moving the unit close to its permanent location, removing all protective packaging, setting in place and cleaning.

- A. Uncrate the machine.
- B. Remove 4 nuts holding the machine to the pallet (Figure 4-1).
- C. Raise the machine, draw out the pallet (Figure 4-2).

When opening the packing, divide packing stuffs per type and get rid of them according to laws in force in machine installation country.

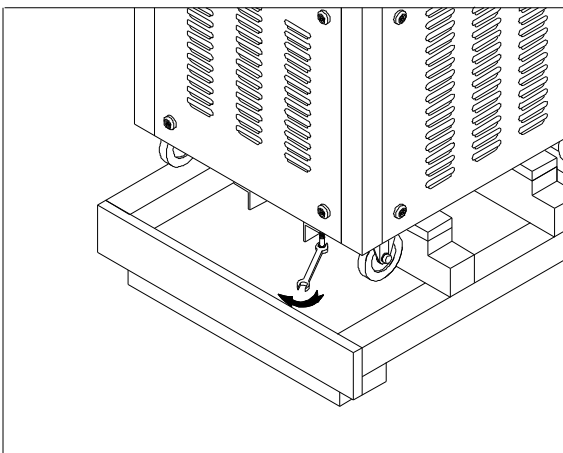

Figure 4-1

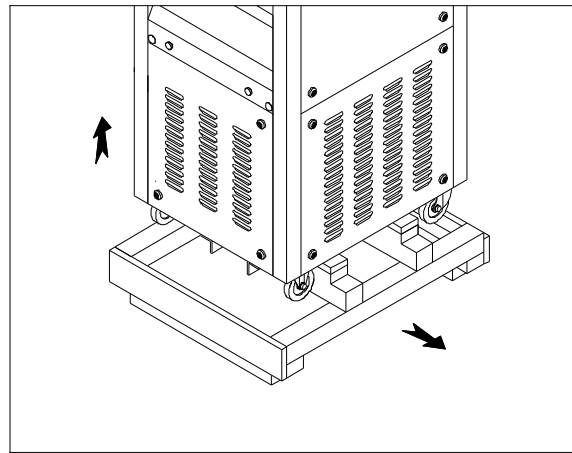

Figure 4-2

- D. The machine required adequate ventilation. A minimum of 152mm of vent space is required for free flow of air. The machine is provided with castors for an easy positioning; a mechanical block system, once engaged, prevents machine from moving and keeps it standstill.

- E. Install the drip pan on the machine (Figure 4-3).

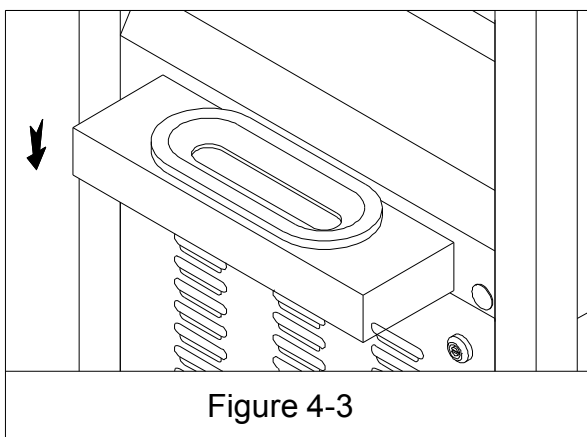

Figure 4-3

F. Connect the power supply. Check the nameplate on the machine for supply. The unit must be connected to three phase wires, one neutral wire and earth wire, otherwise the unit can't start. The unit must be connected to a properly grounded receptacle.

**CAUTION**

**This Equipment Must Be Properly Grounded! Failure To Do So Can Result In Severe Personal Injury From Electrical Shock!**

G. When connect the power supply, the fluorescent display indicate:



H. Press STOP button, then press P button indicate temperature of cylinder and hopper. Figure 4-4

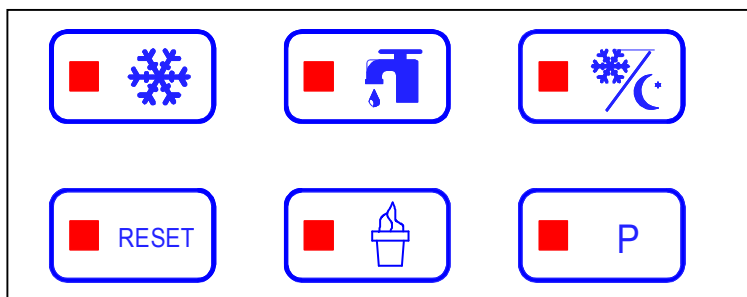
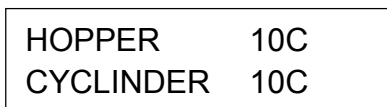

Figure 4-4

**IMPORTANT:** If one or both of two temperature value(s) indicate(s) "00C", you must STOP machine and contact the authorized service technician to check the temperature sensor connection.

**PANEL REMOVAL:**

To remove the panel, using a flat head screwdriver into the panel attaching lock. Turn the lock in the direction shown in Figure 4-5.

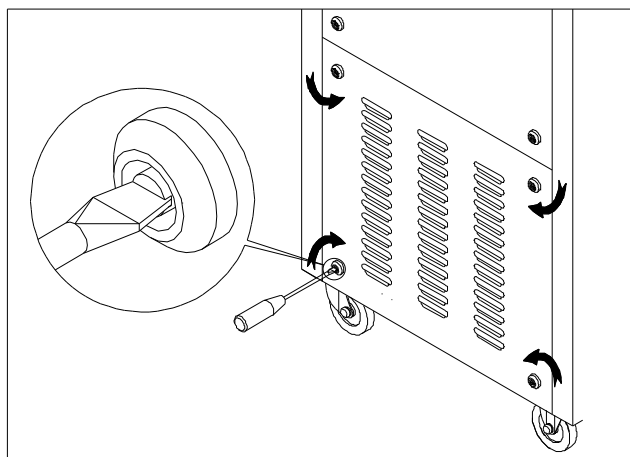

Figure 4-5

Before operating the machine, it is required that the operator know the function of each operating control. Refer to Figure 5-1 Figure 5-2 for location of the controls panel of the machine. It is easy to activate and control all of the machine functions from the front panel.

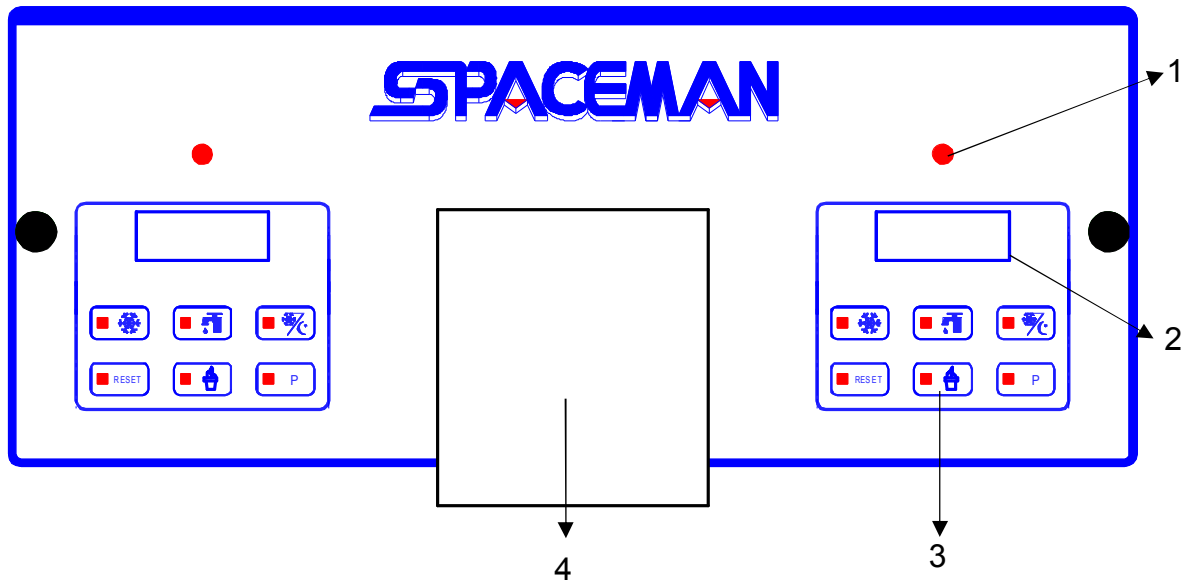

Figure 5-1

Item	Description
1	Indicator Led- "Mix Low"
2	Fluorescent Display
3	Touch Switch Panel
4	Spigot Switch Cover

### Indicator Led-"Mix Low"

When the led is "ON", it indicates that the mix hopper has a low supply of mix and should be refilled as soon as possible. Always maintain at least 2cm of mix in the hopper. If you neglect to add mix, a freeze-up may occur. This will cause eventual damage to the beater assembly, the dispensing door and gear box.

### Fluorescent Display

During normal operation the display is used to indicate function, the temperature of the mix in the hopper and cylinder, the electric current of beater motor, error and warning messages.

Symbol Definitions

To better communicate in the International arena, symbols have replaced words on many of our operator switches. SPACEMAN equipment is designed with these International symbols. The following chart identifies the symbol definitions.

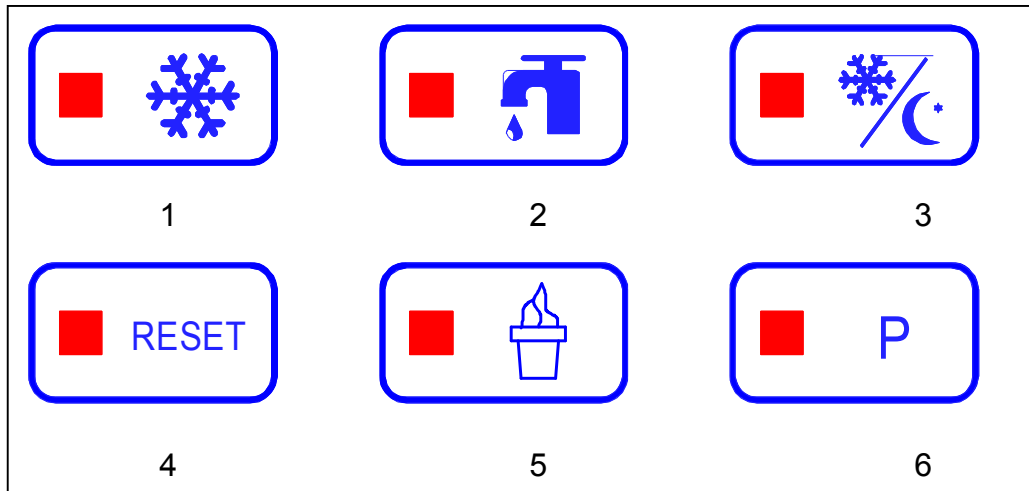

Figure 5-2

Item	Description
1	COOL Button and Led
2	WASH Button and Led
3	STANDBY Button and Led
4	RESET Button
5	ICE CREAM Button and Led
6	P Button

Operating Descriptions

When connect the power supply, the fluorescent display indicate:



RESET BUTTON (Item 4)

Press RESET button to exit current mode, fluorescent display indicates STOP. It is possible to select any machine function. In order to change a function, IT IS ALWAYS NECESSARY to first press RESET button to return STOP.

## WASH BUTTON (Item 2)

1. Press WASH button, the led of WASH comes "ON". The beater motor operate, fluorescent display indicates "WASHING".
2. Press P button, the fluorescent display indicates:

HOPPER	0.0C	→ Indicate present temperature of mix in hopper.
CYLINDER	0.0C	→ Indicate present temperature of mix in cylinder.

3. Press P button once again, the fluorescent display indicates:

CUR.	1.34 / 2.00 A	→ Indicate the electric current of beater motor.
------	---------------	--------------------------------------------------

Number before "/" is present electric current of beater motor.

Number after "/" is maximum electric current of beater motor been set.

4. Press P button once again, fluorescent display indicates "WASHING". Press P button, fluorescent display will cycle from step 2.
5. Press Reset button, the led of WASH comes "OFF", fluorescent display indicates STOP. All function buttons are available.

## COOL BUTTON (Item 1)

1. Press the COOL button, the led of COOL comes "ON". Fluorescent display indicates "COOLING". Beater motor and agitator operate, two refrigeration system is working. One for cylinder to make product, another for hopper to pre-cool mix and keep temperature of mix in hopper is under the default 5°C.
2. When temperature of mix in hopper is 1 degree lower than 4°C, mix hopper refrigeration system automatically stop and automatically start when 1 degree higher than 4°C. The default 4°C can be adjusted in SET MENU.
3. At the same time, refrigeration for cylinder is working until the unit cycles OFF, the product in the freezing cylinder will be at serving viscosity. Raise the draw valve, activating the beater motor, the product flowing from the door spout. The viscosity of product is controlled by electric current of beater motor. The higher electric current is higher viscosity of product. The viscosity can be adjusted in SET MENU.
4. Press P button, the fluorescent display indicates:

HOPPER	0.0C	→ Indicate present temperature of mix in hopper.
CYLINDER	0.0C	→ Indicate present temperature of mix in cylinder.

5. Press P button once again, the fluorescent display indicates:

CUR.	1.34 / 2.00 A
*****	

- Indicate the electric current of beater motor.
- Indicate the scale of viscosity.

When the second line is full by “\*”, the product is at serving viscosity.

6. Press P button once again, fluorescent display indicates “COOLING”. Press P button, fluorescent display will cycle from step 4.
7. Press Reset button, the led of COOL comes “OFF”, fluorescent display indicates STOP. All function buttons are available.

### STANDBY BUTTON (Item 3)

During long “No Sale” periods, the unit can be placed into the Standby mode. This maintains product temperatures below 5°C in both the hopper and the freezing cylinder, and helps prevent overheating and product breakdown. You will save significantly on energy consumption, as the compressor runs only for the time strictly necessary in order to keep product at its correct temperature.

1. Press STANDBY button, the led of STANDBY comes “ON”. Fluorescent display indicates:

STANDBY
NOT DRAW

2. Press P button, fluorescent display indicates:

HOPPER	0.0C
CYLINDER	0.0C

- Indicate current temperature of mix in hopper.
- Indicate current temperature of mix in cylinder.

3. Indicate above menu for 5 seconds, fluorescent display will return to:

STANDBY
NOT DRAW

4. If no any button is pressed in 10 minutes, fluorescent display will enter save mode, led of background will OFF. Till press any button except Reset button, led of background will ON.
5. Press Reset button, the led of STANDBY comes “OFF”, fluorescent display indicates STOP. All function buttons are available.

### ICE CREAM BUTTON (Item 5)

1. Press ICE CREAM button, It is used to check the number of servings dispensed from the machine.

The fluorescent display indicates:

Today:	00000	→	Indicate the quantity of ice cream serviced today.
Total:	0000000	→	Indicate the quantity of ice cream serviced total

2. Indicate above menu for 5 seconds, fluorescent display will return to:

HOPPER	0.0C
CYLINDER	0.0C

3. Press Reset button, fluorescent display indicates STOP. All function buttons are available.

### P BUTTON (Item 6)

1. At COOL and WASH mode, pressing P button will change the display menu between temperature and electrical current.
2. At STANDBY mode, pressing P button indicate temperature for 5 seconds.
3. At STOP mode, pressing P button indicate temperature.

### SET MENU

The SET Menu is used to enter the parameter setting. To access the Menu, press and hold the RESET button for 3 seconds.

In the Menu program, the RESET, COOL, STANDBY, P, WASH and ICE CREAM button will function as menu keys.

- STANDBY BUTTON** - increases the value above the cursor.
- P BUTTON** - decreases the value above the cursor.
- RESET BUTTON** - change screen of setting.
- COOL BUTTON** - change item of setting.
- WASH BUTTON** - not save the setting and exit.
- ICE CREAM BUTTON** - save the setting and exit.

1. At STOP mode, press and hold the RESET button for 3 seconds, fluorescent display indicates:

VISCOSITY SET
CURRENT: 2.00

- The above value is the maximum viscosity setting. When the electrical current achieves the value, the product is at serving viscosity, stop the refrigeration of cylinder. The higher electric current is higher viscosity of product.

- Press the STANDBY button to increase the value.
- Press the P button to decrease the value.

2. Press RESET button once, fluorescent display indicates:

MIX TEMPERATURE
L            SET: 4.5C

- In COOL and STANDBY cycle, machine will start to cool mix in hopper when temperature of mix in hopper is 1 degree higher than above value. And stop it when the temperature is 1 degree lower. In the STANDBY cycle, same function for mix in cylinder.
- Press the STANDBY button to increase the value.
- Press the P button to decrease the value.

3. Press RESET button once, fluorescent display indicates:

2011 /01 /16
14 : 47 :58

- Set the date and time.
- Press the STANDBY button to increase the value. Press the P button to decrease the value.
- Press COOL button to set next parameter.
- You must press ICE CREAM button for 3 second to save the adjustment.

4. Press RESET button once, fluorescent display indicates:

P: 0 00 : 00
P: 0 00 : 00

- Set the automatic program at set time.
- For example:  
P: 1 08:00 start COOL mode at 08:00 every day.  
P: 3 22:00 start STANDBY mode at 22:00 every day.
- Press the STANDBY button to increase the value. Press the P button to decrease the value.
- Press COOL button to set next parameter.
- P: 0 is no automatic program. There are 1 hour at least between COOL and other program.
- You must press ICE CREAM button for 3 second to save the adjustment.

5. Press RESET button once, fluorescent display indicates:

<p style="text-align: center;">ENTER CODE 0 0 0 0</p>
-----------------------------------------------------------

- It is requirement of service set pass code

6. Press RESET button, fluorescent display will cycle from step 1.

7. If exit SET MENU not save setting, press WASH button, fluorescent display indicates:

<p style="text-align: center;">STOP NOT SAVE</p>
------------------------------------------------------

8. If save setting and exit SET MENU, press and hold ICE CREAM button for 3 seconds, fluorescent display indicates:

<p style="text-align: center;">STOP SAVE OK</p>
-----------------------------------------------------

9. Press Reset button, fluorescent display indicates STOP. All function buttons are available.

## FAULT DESCRIPTION

Listed below are the variable fault messages which will appear, along with an explanation for the corrective action.

If the machine has been stopped a long time due to a failure, it is necessary that you check product temperature before starting the sale again; if the temperature is over +6°C, the machine must be emptied, cleaned and sanitized, and filled up with new fresh mix.

1. In the course of any mode, press P button indicate temperature of cylinder and hopper.

**IMPORTANT:** If one or both of two temperature value(s) indicate(s) "00C" without any change for more 2 minutes, you must STOP machine and contact the authorized service technician to check the temperature sensor.

HOPPER	0.0C
CYCLINDER	0.0C

2. In COOLING cycle, if fluorescent display appears:

STOP 1 LOW TEM. PROTECT
----------------------------

The temperature of cylinder achieves or lower than the lowest temperature setting. The led of COOL and STANDBY will be sparked, compressor stop, beater motor working.

Press RESET button, fluorescent display indicates STOP.

Lower viscosity setting in SET MENU item1 or contact the authorized service technician to check lower the temperature of cylinder protection setting

Press the WASH button and observe the machine's performance.

If the beater motor is turning properly, press the RESET button.

Press COOL button to resume normal operation.

If no any button is pressed in 10 minutes, machine will enter STANDBY mode automatically.

3. In COOLING cycle, if fluorescent display appears:

STOP 2 MOTOR OVERLOAD
--------------------------

The electrical current of beater motor achieves or more than highest current setting, the led of COOL will be sparked, machine stop.

Press RESET button, fluorescent display indicates STOP.

Lower viscosity setting in SET MENU item1 or contact the authorized service technician to check highest current setting.

Press the WASH button and observe the machine's performance.

If the beater motor is turning properly, press the RESET button.

Press other button to resume normal operation.

4. In COOLING cycle, if fluorescent display appears:

LOW MIX ADD MIX
--------------------

The led of Mix Low will be sparked, it indicates that the mix hopper has a low supply of mix and should be refilled as soon as possible.

Otherwise machine stop refrigeration of cylinder after Low mix delay. The time of Low mix delay will be setting by service technician.

When you add enough mix, the led of Mix Low OFF, machine will enter COOL cycle automatically.

## 5. Reset Button

The reset protects the beater motor from an overload condition. If an overload occurs, the reset mechanism will trip. The machine shuts down, it appears no power supply.

Firstly find out the reason of protection, solve problem.

Check the power supply, make sure properly connected with power supply.

Lower viscosity setting in SET MENU item1.

Then press the reset button (blue color button) in the thermal overload relay.

Figure 5-3.

**WARNING:**

Do not use metal objects to press the reset button. Failure to comply may result in severe personal injury or death.

Press the WASH button and observe the machine's performance. If the beater motor is turning properly, press the RESET button to cancel the cycle. Press other button to resume normal operation. If the machine shuts down again, contact your authorized service technician.

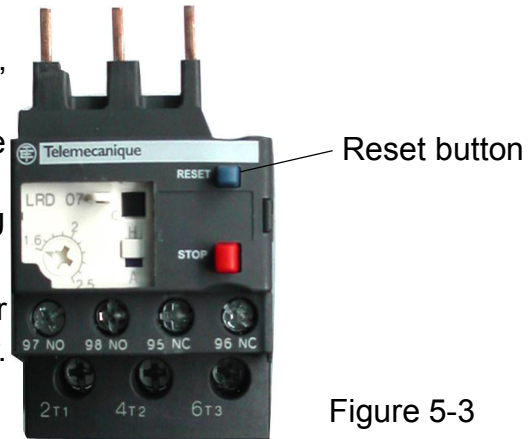

Figure 5-3

## 6. PRESSURE SWITCH

It protects the refrigeration system and causes the compressor to stop if the pressure of the system exceeds the pressure switch setting value. This may occur especially due to a lack of air circulation problems. The switch resets itself manually.

**WARNING:**

If the compressor runs for an excessive time or stops and starts repeatedly, this indicates insufficient condensation; check the causes and contact authorized service technician.

**BEATER AND DISPENSING DOOR**

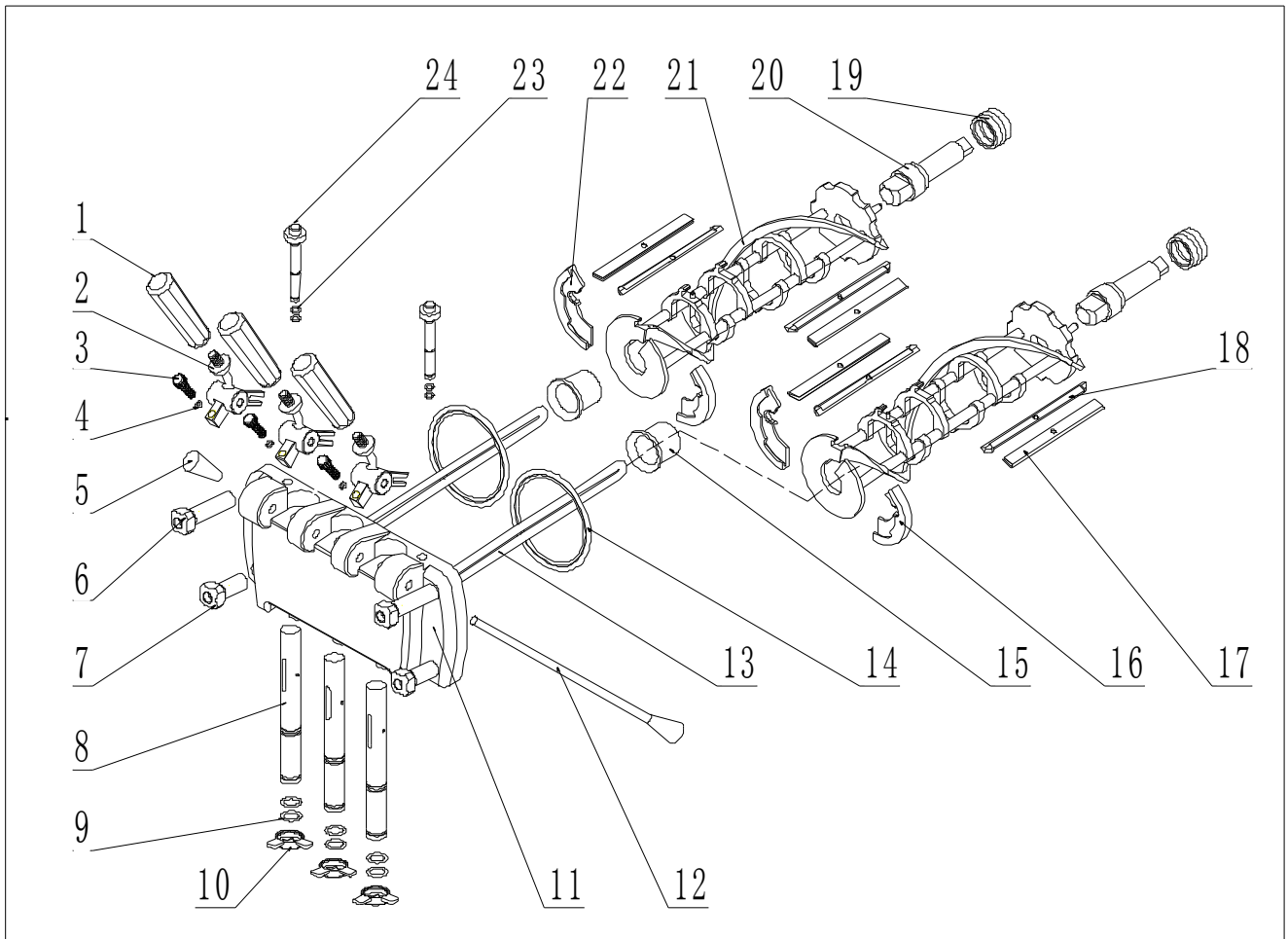

Item	DESCRIPTION	NUMBER	ITEM	DESCRIPTION	NUMBER
1	Dispensing handle	6378206008	13	Beater rod	6378000012
2	Handle stand	6378206111	14	Seal of dispensing door	6378020601
3	Screw adjustment	6378206112	15	Front bearing	6378207030
4	Screw adjustment seal	6378206113	16	Shoe-Right	6378207032
5	Retention nut	6378206009	17	Clip-Scraper	6378207028
6	Attaching nuts (Longer)	6378000081	18	Blade-Scraper-Plastic	6378207029
7	Attaching nuts (Shorter)	6378000082	19	Rear seal of beater	6378207026
8	Draw valve	6378206004	20	Rear shell bearing	6378207027
9	Draw valve seal	6378206006	21	Beater	6378207000
10	Design Cap	6378020902	22	Shoe-Left	6378207031
11	Dispensing door	6378206001	23	Plug-Prime seal	6378206201
12	Dispensing retention	6378020606	24	Plug-Prime	6378206202

Each unit stores mix in a hopper. The mix then flows through an air pump down into the freezing cylinder. It has one 3.2 liter capacity freezing cylinders and a 10 liter mix hopper.

We begin our instructions at the point where we enter the store in the morning and find the parts disassembled and laid out to air dry from the previous night's cleaning.

These opening procedures will show you how to assemble these parts into the machine, sanitize them, and prime the machine with fresh mix in preparation to serve your first portion.

If you are disassembling the machine for the first time or need information to get to this starting point in our instructions, turn to page 25, "Disassembly", and start there.

Only there is raw material in the mix hopper can you run the machine "COOL". You should STOP the machine if there is no raw material in the hopper.

### ASSEMBLY

Failure to follow this instruction may result in electrocution or injury to fingers or hands from hazardous moving parts.

**Note:** When lubricating parts, use an approved food grade lubricant.

#### Step 1

To install the drive shaft, lubricate the groove and shaft portion that comes in contact with the bearing on the beater drive shaft. Heavily lubricate the inside portion of the boot seal and also lubricate the flat end of the boot seal that comes in contact with the rear shell bearing. Apply an even coat of lubricant to the shaft. DO NOT lubricate the hex end.

Figure 6-1

**Note:** To ensure the mix does not leak out of the back of the freezing cylinder, the middle section of the boot seal should be convex or extend out from the seal. If the middle section of the boot seal is concave or extending into the middle of the seal, turn the seal inside out.

Insert the beater drive shaft through the rear shell bearing in the freezing cylinder and engage the hex end firmly into the drive coupling. Figure 6-2

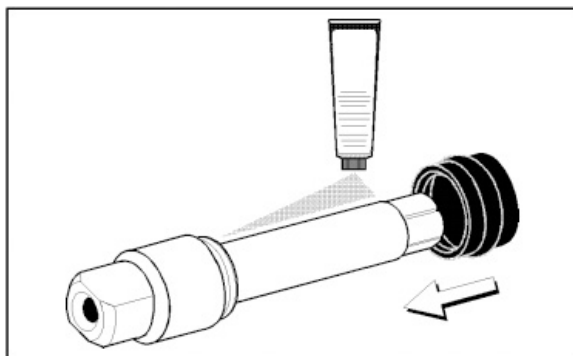

Figure 6-1

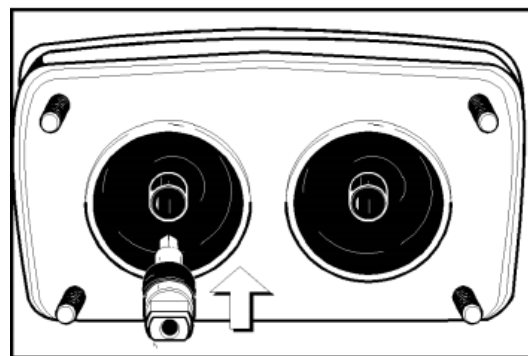

Figure 6-2

**Step 2**

Install the beater assembly. First check the scraper blades for any nicks or signs of wear. If any nicks are present, replace both blades. Figure 6-3

If the blades are in good condition, install the scraper blade clips on the scraper blades. Place the rear scraper blade over the rear holding pin on the beater. Figure 6-4.

**Note:** The hole on the scraper blade must fit securely over the pin to prevent costly damage.

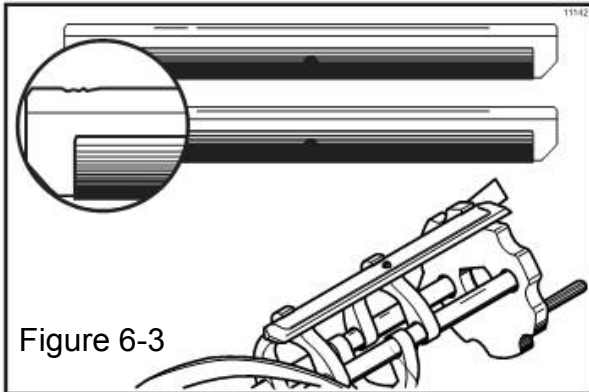

Figure 6-3

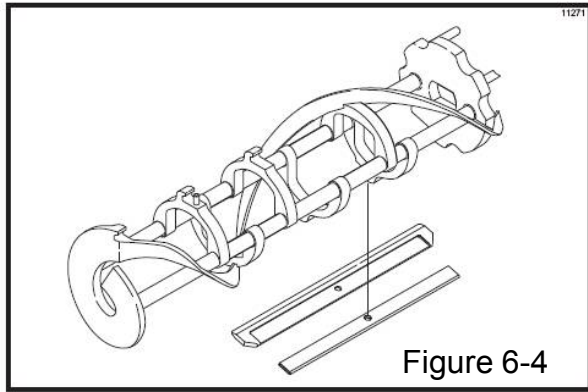

Figure 6-4

Holding the rear blade on the beater, slide it into the freezing cylinder half way. Install the front scraper blade over the front holding pin. Figure 6-5

Install the beater shoes. Figure 6-6

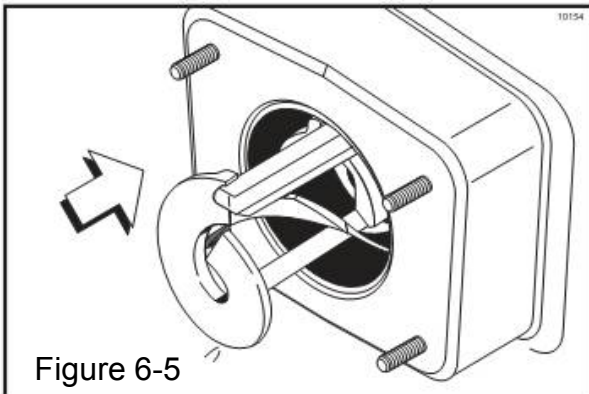

Figure 6-5

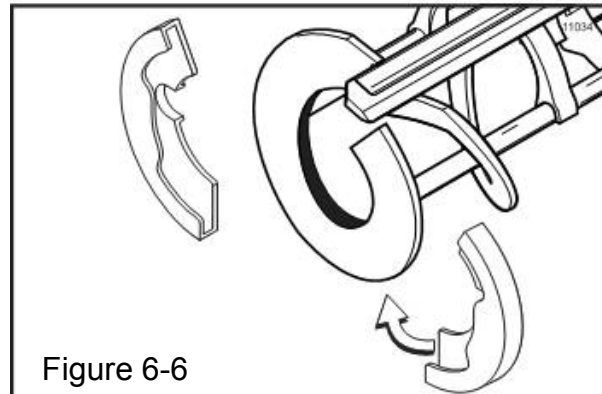

Figure 6-6

Slide the beater assembly the rest of the way into the freezing cylinder. Make sure the beater assembly is in position over the drive shaft. Turn the beater slightly to be certain that the beater is properly seated. When in position, the beater **will not** protrude beyond the front of the freezing cylinder.

**Step 3**

Assemble the dispensing door. Place the large rubber gaskets in the grooves on the back side of the dispensing door.

Slide the white plastic front bearings over the baffle rods, making certain that the flanged end of the bearing is resting against the dispensing door. Figure 6-7

**DO NOT** lubricate the gaskets or front bearings.

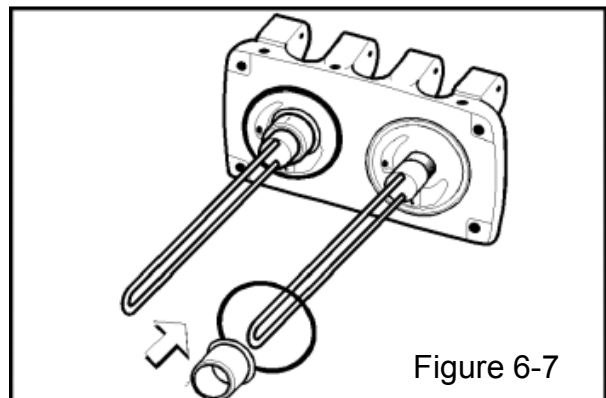

Figure 6-7

Slide the o-rings into the grooves on the prime plugs. Apply an even coat of lubricant to the o-rings and shafts. Figure 6-8

Insert the prime plugs into the holes at the top of the freezer door and push down.

Figure 6-9

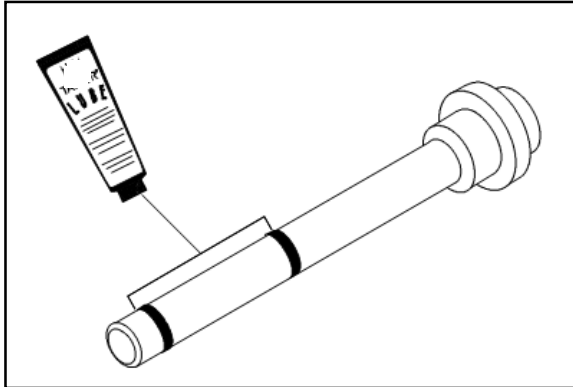

Figure 6-8

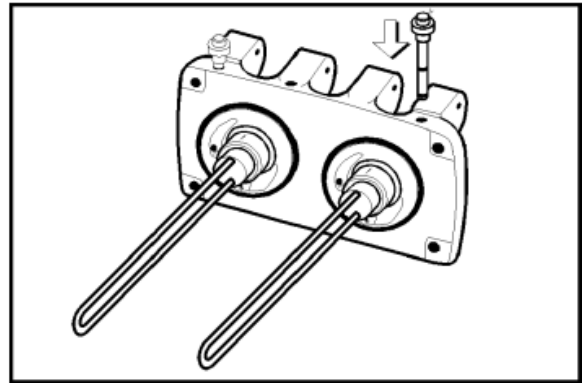

Figure 6-9

#### Step 4

Install the freezer door. Insert the baffle rods through the beaters in the freezing cylinders. With the door seated on the freezer studs, install the hand screws. Tighten equally in a crisscross pattern to insure the door is snug. Figure 6-10

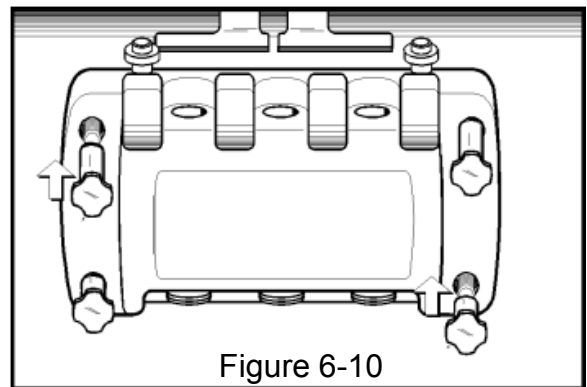

Figure 6-10

#### Step 5

Install the draw valves. Slide the two o-rings into the grooves on the draw valve(s) and lubricate. Figure 6-11

Lubricate the inside of the freezer door spouts, top and bottom, and insert the draw valves from the bottom until the slot in the draw valves comes into view. Figure 6-12

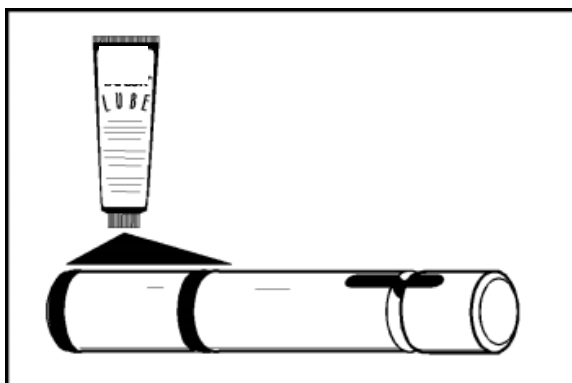

Figure 6-11

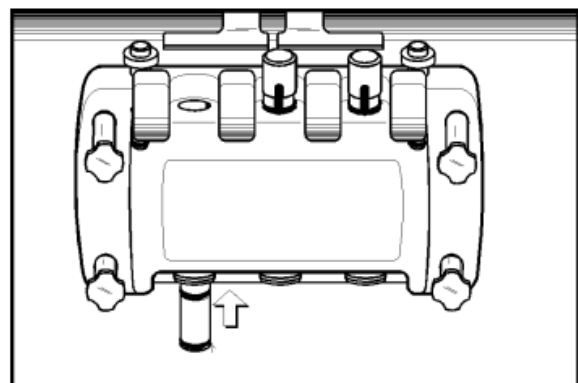

Figure 6-12

**Step 6**

Install the adjustable draw handles. Slide the o-rings into the grooves on the pivot pins and lubricate. Figure 6-13

Slide the fork of the draw handles in the slot of the draw valves. Secure with pivot pin. Figure 6-14

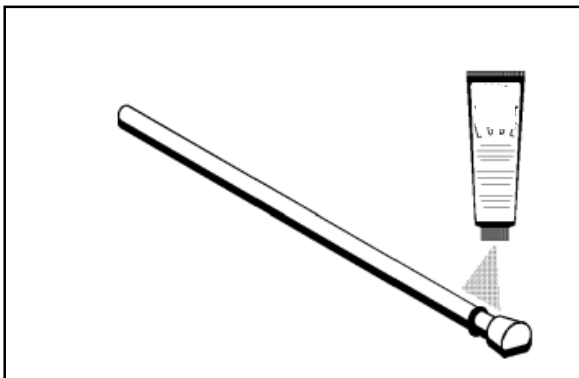

Figure 6-13

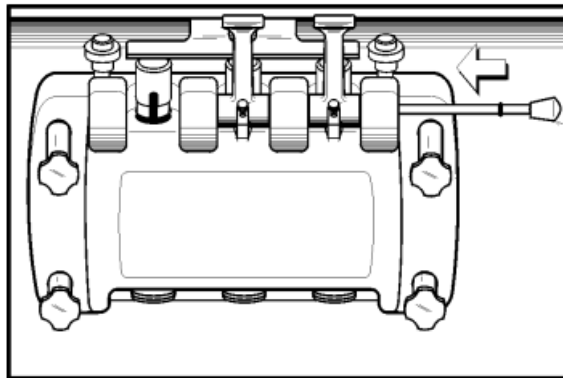

Figure 6-14

Note: These units feature adjustable draw handles to provide the best portion control, giving a better consistency quality to your product, and controlling costs. The draw handles can be adjusted for different flow rates. See page 20 for more information on adjusting these handles.

**Step 7**

Snap the design cap over the bottom of each door spout. Figure 6-15

**Step 8**

Install the rear drip pan. Slide the rear drip pan into the hole in the side panel. Figure 6-16

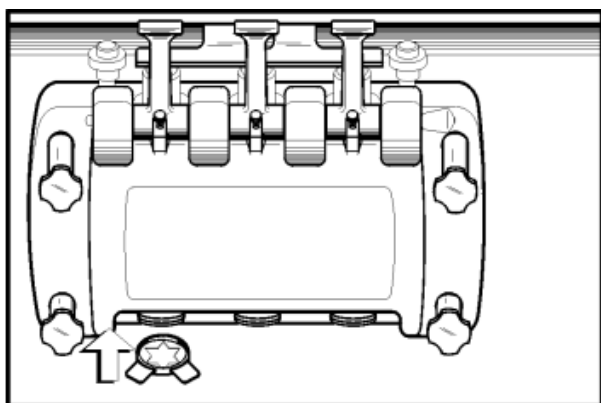

Figure 6-15

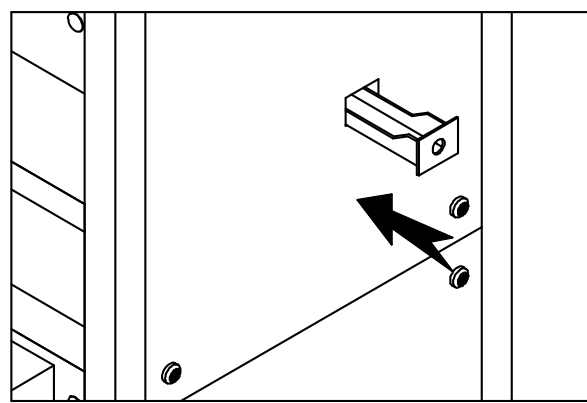

Figure 6-16

**Step 9**

Install the front drip tray. See page 5 Figure 4-3.

**Step 10**

Lay the air tube in the bottom of the mix hopper for sanitizing

**Note:** These units feature adjustable draw handles to provide the best portion control, giving a better consistency quality to your product, and controlling costs. The draw handles can be adjusted for different flow rates.

The draw handle should be adjusted to provide a flow rate of 5 to 7-1/2oz. of product per 10 seconds. To increase the flow rate, turn the screw counterclockwise. Turn the screw clockwise to decrease the flow rate.

Figure 6-17

During “Sanitizing” and “Rinsing”, the flow rate can be increased by removing the pivot pin and placing the restrictive bar on the TOP. When drawing product, always place the restrictive bar on the bottom.

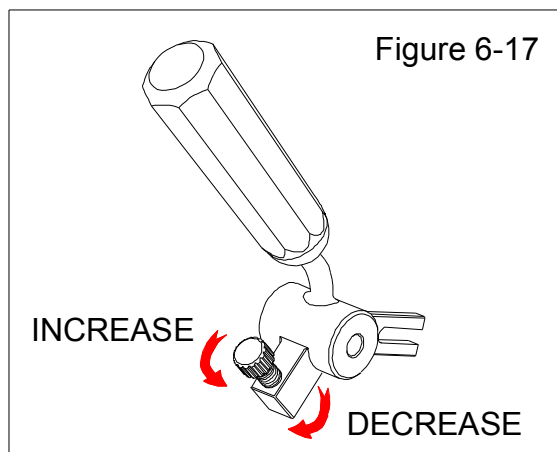

## SANITIZING

### Step 1

Prepare 7.6 liters of an approved 100PPM sanitizing solution. USE WARM WATER AND FOLLOW THE MANUFACTURER’S SPECIFICATIONS.

### Step 2

Pour 7.6 liters of sanitizing solution into the hopper and allow it to flow into the freezing cylinder.

### Step 3

While the solution is flowing into the freezing cylinder, brush clean the mix hopper. When cleaning the hopper, take particular care in brushing the mix level sensing stem on the side wall of the hopper, the mix inlet hole and the air tube.

### Step 4

Press Power ON, press the Wash Button. This will cause the sanitizing solution in the freezing cylinder to be agitated. Allow it to agitate for five minutes.

### Step 5

Place an empty pail beneath the door spout, and open the prime plug. Figure 6-18  
When a **steady** stream of sanitizing solution is flowing from the prime plug opening in the bottom of the freezer door, lower the draw handle. Draw off all the sanitizing solution. Figure 6-19

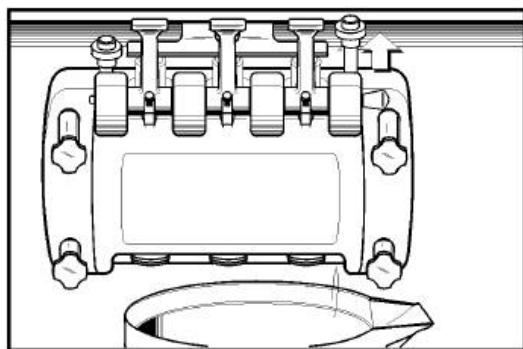

Figure 6-18

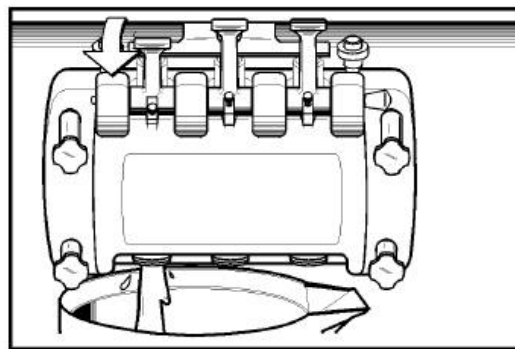

Figure 6-19

**Note:** Momentarily pull the center draw handle down to sanitize the center door spout.

Once the sanitizer stops flowing from the door spout, press WASH button again, force out remaining sanitizing solution for 2 seconds. Raise the draw handle and press the RESET button, cancelling WASH operation.

**Note:** You have just sanitized the freezer. **Be sure your hands are sanitized** before continuing these instructions.

### Step 6

Lubricate the o-rings in the mix inlet hole of the hopper and seal in the connect tube (Item 16) of air pump.

### Step 7

Place the agitator on the agitator drive shaft housing.  
Figure 6-20

**Note:** If agitator should stop turning during normal operation, with sanitized hands, remove agitator from agitator drive shaft housing and brush clean with sanitizing solution. Install the agitator back onto the agitator drive shaft housing.

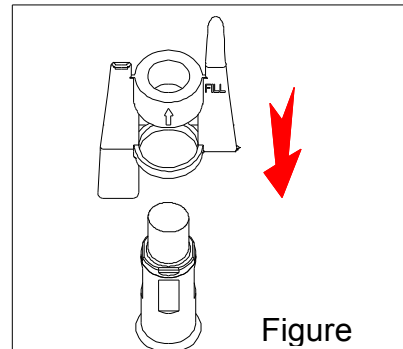

Figure

### Step 8

Repeat Steps 1 through 6 for the second freezing cylinder.

## PRIMING

Prime the machine as close as possible to the time of first product draw.

- Never:**
1. **Too much water in the mix.**
  2. **COOL button "ON" when only water in the hoppers and cylinder.**
  3. **COOL button "ON" when no mix in the hoppers and cylinder.**

### Step 1

Prepare 10 liters of fresh mix.

With a pail beneath the door spout, lower the draw handle. Be sure the prime plug is still in the UP position. Pour the fresh mix into the mix hopper and allow it to flow into the freezing cylinder. This will force out any remaining sanitizing solution.

When full strength mix is flowing from the door spout, raise the draw handle. Figure 6-21

**Note:** Use only **fresh** mix when priming the freezing cylinder.

### Step 2

Once a **steady** stream of mix starts to flow from the prime plug opening in the bottom of the freezer door, push down the prime plug. Figure 6-22. Rinse the prime plug hole area with water. Remove the pail and discard the mix and the sanitizer

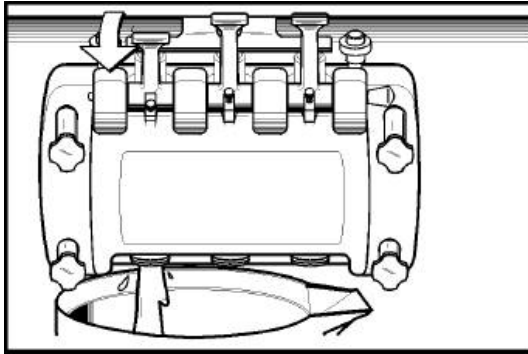

Figure 6-21

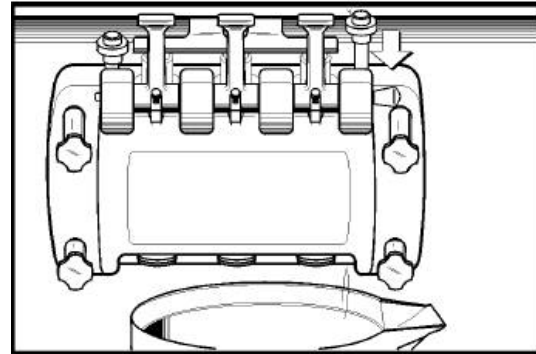

Figure 6-22

**Step 3**

Install the pressure tube (item13) from the sanitizing solution and insert it to mix inlet hole on bottom of hopper.

**Step 4**

Press the WASH button. The WASH led will come ON indicating the agitator and beater motor operating to flow the mix into cylinder

**Note:** Insure enough mix in hopper. If the Led-"Mix Low" comes on, the hopper should be refilled as soon as possible. Otherwise will be caused eventual damage to the beater assembly, the dispensing door and gear box.

**Step 6**

Repeat Steps 1 through 5 for the second freezing cylinder.  
Connect the pressure tube:

**Step 8**

Press the COOL button, the COOL led will come ON indicating the main refrigeration system and mix refrigeration system are operating. When the unit cycles off, the product will be at serving viscosity.

**Step 9**

Place the mix hopper cover in position over the mix hopper.

**Note:** Insure enough mix in hopper. If the Led-"Mix Low" comes on, the hopper should be refilled as soon as possible. Otherwise will be caused eventual damage to the beater assembly, the dispensing door and gear box.

**STANDBY CYCLE**

During long "No Sale" periods, the unit should be placed into the Standby mode. This maintains product temperatures below 4°C in both the hopper and the freezing cylinder, and helps prevent overbeating and product breakdown.

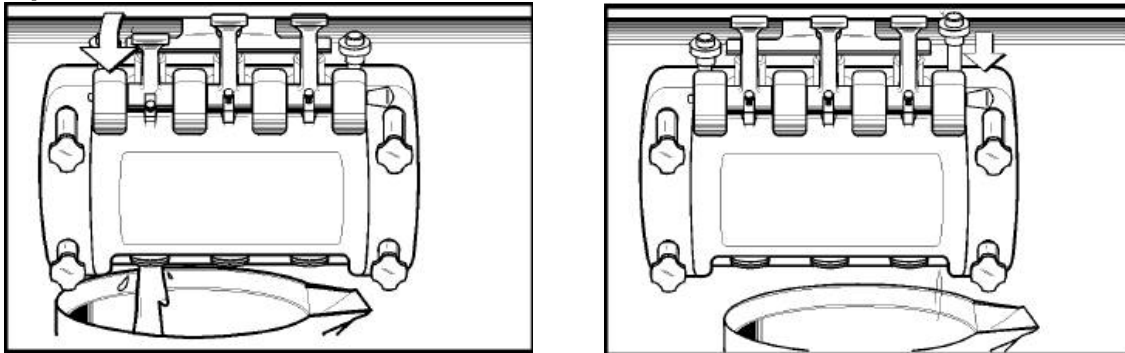
**Step 1**

Press RESET button, place machine in STOP mode.

**Step 2**

Press STANDBY button. The STANDBY led will come ON, machine enter automatic STANDBY cycle.

**Step 3**

To recover Sale, press RESET button, exit STANDBY mode, then press COOL button.

**MANUAL BRUSH CLEANING**

To disassemble this machine, the following items will be needed:

- Cleaning pails
- Sanitized stainless steel rerun can with lid
- Necessary brushes
- Cleaner
- Single service towels

**DRAINING PRODUCT FROM THE FREEZING CYLINDER**

**Step 1**

Press RESET button place machine in STOP mode. Press WASH button in "ON" position as far ahead of cleaning time as possible. This will allow frozen product to soften for easier cleaning.

**Step 2**

Remove the hopper covers.

**Step 3**

Pull upward the agitators from the agitator drive shaft housings.

**Step 4**

Press WASH button.

**Step 5**

With a sanitized pail beneath the door spout, lower the draw handle and drain the remaining product from the freezing cylinder and the mix hopper.

**Step 6**

When the flow of product stops, press the "RESET" button, and raise the draw handle. If local health codes permit, empty the rerun into a sanitized stainless steel can. Cover the container and place it in the refrigerator.

**Step 7**

Pull the connect tube (Item 16) from bottom of hopper. Take these parts to the sink for cleaning.

**Step 8**

**Repeat Steps 1 through 8** for the other side of the freezer

**RINSING****Step 1**

Pour warm, clean water into the mix hopper. With the brushes, scrub the mix hopper, the mix level sense, the outside of the agitator drive shaft housing and the mix inlet hole.

**NOTE:** Do not brush clean the mix inlet hole while the machine is in the WASH mode.

**Step 2**

With a pail beneath the door spout, open the draw valve and press the WASH button.

**Step 3**

Drain all the rinse water from the door spout. Close the draw valve and press the RESET button, cancelling the WASH mode. Repeat this procedure until the rinse water being discharged is clear.

### **HOPPER CLEANING**

#### **Step 1**

Prepare an approved cleaning solution. USE WARM WATER AND FOLLOW THE MANUFACTURE'S SPECIFICATIONS.

#### **Step 2**

Pour the cleaning solution to the mix hopper and allow it to flow into the freezing cylinder.

#### **Step 3**

Using the brush, clean the mix hopper, mix level sensing, the outside of the agitator drive shaft housing and the mix inlet hole.

**NOTE:** Do not brush clean the mix inlet hole while the machine is in the WASH mode.

#### **Step 4**

Press the Wash Button. This will cause the cleaning solution in the freezing cylinder to come in contact with all areas of the freezing cylinder.

#### **Step 5**

Place an empty pail beneath the door spout. Draw off all the cleaning solution. When the solution stops flowing from the door spout, close the draw valve and press the RESET Button cancelling the "WASH" mode.

**Repeat Steps 1 through 5** for the other side of the freezer.

#### **Step 6**

Disconnect the power supply of the machine before disassembling the machine.

### **DISASSEMBLY**

**BE SURE THE POWER SUPPLY IS DISCONNECTED TO ELIMINATE THE CHANCE OF MOVING PARTS. CHECK TO MAKE SURE NO LEDS ARE LIT ON THE CONTROL PANEL AND FLUORESCENT DISPLAY.**

#### **Step 1**

Remove the hand screws, dispensing door, beater and scraper blades, and drive shaft with drive shaft seal from the freezing cylinder.

#### **Step 2**

Remove the scraper blade clips from the scraper blades.

#### **Step 3**

Remove the drive shaft seal from the drive shaft.

#### **Step 4**

Remove the dispensing door gasket, front bearing, pivot pin, draw handle, and draw valve. Remove the two o-rings from the draw valve. Remove the design cap.

**NOTE: To remove the O-ring, use a single service towel to grasp the O-ring.**

Apply pressure in an upward direction until the O-ring pops out of its groove. With the other hand, push the top of the O-ring forward, and it will roll out of the groove and can be easily removed. If there is more than one O-ring to be removed, always remove the rear O-ring first. This will allow the O-ring to slide over the forward rings without falling into the open grooves.

**Step 5**

Remove the front drip tray and rear drip pan.

**NOTE:** If the rear drip pan are filled with an excessive amount of mix, it is an indication that the drive shaft seal, or o-ring should be replaced or properly lubricated.

**BRUSH CLEANING****Step 1**

Prepare a sink with an approved cleaning solution. USE WARM WATER AND FOLLOW THE MANUFACTURER'S SPECIFICATIONS

**IMPORTANT:** Follow label directions, as too STRONG of a solution can cause parts damage, while too MILD of a solution will not provide adequate cleaning. Make sure all brushes are available for brush cleaning.

**Step 2**

Remove the O-rings from the drive shaft.

**Note:** To remove the O-ring, use a single service towel to grasp the O-ring. Apply pressure in an upward direction until the O-ring pops out of its groove. With the other hand, push the top of the O-ring forward, and it will roll out of the groove and can be easily removed. If there is more than one O-ring to be removed, always remove the rear O-ring first. This will allow the O-ring to slide over the forward rings without falling into the open grooves.

**Step 3**

Remove the scraper blade clips from the scraper blades.

**Step 4**

From the freezer doors remove the gaskets, front bearings, pivot pins, draw handles, draw valves, prime plugs, and the design caps.

Remove all o-rings.

**Step 5**

Return to the freezer with a small amount of cleaning solution. With the black bristle brush, brush clean the rear shell bearing at the back of the freezing cylinder. Figure 6-23

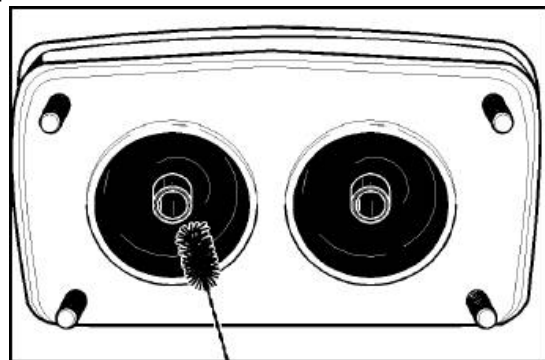

Figure 6-23

**Step 6**

Thoroughly brush clean all disassembled parts in the cleaning solution. Make sure all lubricant and mix film is removed. Take particular care to brush clean the draw valve core in the freezer door. Place all the cleaned parts on a clean, dry surface to air dry overnight.

**Step 7**

Wipe clean all exterior surfaces of the freezer.

### During cleaning and sanitizing

Cleaning and sanitizing schedules are governed by your State or local regulatory agencies and must be followed accordingly. The following check points should be stressed during the cleaning and sanitizing operations.

**CLEANING AND SANITIZING MUST BE PERFORMED EVERY 14 DAYS.  
ALWAYS FOLLOW LOCAL HEALTH CODES.**

### Troubleshooting Bacterial Count

1. Thoroughly clean and sanitize the machine regularly, including complete disassembly and brush cleaning.
2. Use brushes for thorough cleaning. Use the brush to clean the mix inlet hole which extends from the mix hopper down to the rear of the freezing cylinder. Use the brush to thoroughly clean the rear of the freezing cylinder. Be sure to have a generous amount of cleaning solution on the brush.
3. IF LOCAL HEALTH CODES PERMIT THE USE OF RERUN, make sure the mix rerun is stored in a sanitized, covered stainless steel container and is used the following day. DO NOT prime the machine with rerun. When using rerun, skim off the foam and discard. Mix the rerun with fresh mix in a ratio of 50/50 during the day's operation.
4. Discard remaining mix from the freezer during "Cleaning Procedures".
5. Properly prepare the cleaning and sanitizing solutions. Read and follow label directions carefully. Too strong of a solution may damage the parts and too weak of a solution will not do an adequate job of cleaning or sanitizing.
6. The temperature of the mix in the hopper and cylinder should be below 4 °C.

### Regular Maintenance Checks

1. Replace scraper blades that are nicked or damaged. Before installing the beater assembly, be certain that scraper blades are properly attached to the helix.
2. Check the rear shell bearing for signs of wear (excessive mix leakage in rear drip pan) and be certain it is properly cleaned.
3. Using a screwdriver and cloth towel, keep the rear shell bearing and the female hex drive socket clean and free of lubricant and mix deposits.
4. Dispose of O-rings or seals if they are worn, torn, or fit too loosely, and replace with new ones.
5. If an overload condition occurs frequently, maybe the belt is worn, torn, or fit too loosely. Dispose of the belt and replace with new ones.
6. Follow all lubricating procedures as outlined in ASSEMBLY.
7. This machine is air cooling, check the condenser for an accumulation of dirt and lint. A dirty condenser will reduce the efficiency and capacity of the machine. Condensers should be cleaned monthly with a soft brush. Never use screwdrivers or other metal probes to clean between the fins. Failure to comply may result in electrocution. Figure 7-1

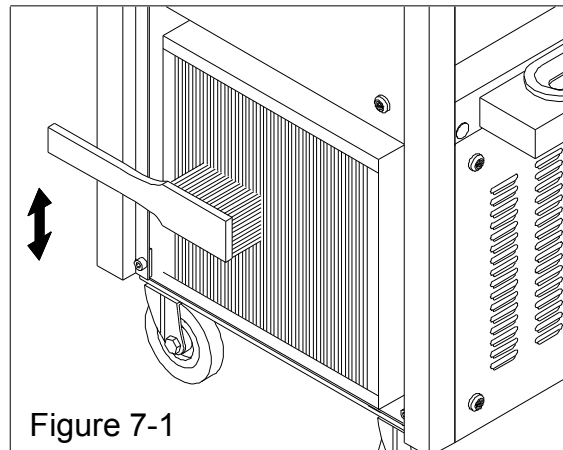

### Winter Storage

If the place of business is to be closed during the winter months, it is important to protect the machine by following certain precautions, particularly if the building is subject to freezing conditions.

Disconnect the machine from the main power source to prevent possible electrical damage.

Your local Distributor can perform this service for you.

Wrap detachable parts of the machine such as the beater, blades, drive shaft, and dispensing door. Place these parts in a protected, dry place. Rubber trim parts and gaskets can be protected by wrapping them with moisture-proof paper. All parts should be thoroughly cleaned of dried mix or lubrication which attract mice and other vermin.

<b>PROBLEM</b>	<b>PROBABLE CAUSE</b>	<b>REMEDY</b>	<b>PAGE REF.</b>
1. No product being dispensed	a. The power supply is not connected correctly.	a. Connect power supply correctly.	1
	b. Low on mix. The MIX LOW led is on.	b. Add the mix to the hopper.	23
	c. The beater motor overload.	c. Reset thermal overload relay.	15
	d. Machine is unplugged.	d. Plug machine into the wall receptacle	1
	e. Circuit breaker is off or the fuse is blown.	e. Turn the breaker "ON" or replace the fuse.	--
	f. The dispensing door is incorrectly assembled.	f. Install dispensing door correctly.	20
	g. Restriction in the door spout.	g. Remove the draw handle and raise the draw valve all the way up to remove restriction. Never put objects or fingers in door spout.	22
	h. Freeze-up in mix inlet hole.	h. Call service technician to adjust the mix hopper temperature.	--
	i. The air pump is installed incorrectly.	i. Install pump correctly.	18
2. The machine not operate in the "COOL" mode.	a. Machine is unplugged.	a. Connected. Press the reset button.	1
	b. The circuit breaker is off or the fuse is blown.	b. Turn the breaker "ON" or replace the fuse.	--
	c. The beater motor overload.	c. Reset thermal overload relay.	15
3. The product is too hard	a. The viscosity needs adjustment.	a. Adjust the hardness setup.	12
	b. Insufficient mix in the freezing cylinder.	b. Add the mix to the hopper.	23

## Section 8

## Troubleshooting Guide

<b>PROBLEM</b>	<b>PROBABLE CAUSE</b>	<b>REMEDY</b>	<b>PAGE REF.</b>
4. The product is too soft	a. The viscosity needs adjustment.	a. Adjust the hardness setup.	12
	b. Not enough air space around unit.	b. Allow for adequate air flow across condenser.	5
	c. Worn scraper blades.	c. Replace regularly.	20
	d. Dirty condenser	d. Clean regularly.	34
	e. Loss of refrigerant.	e. Call service technician.	--
	f. Mix is out of date.	f. Use only fresh mix.	--
	g. Machine has run too long without dispensing ice cream.	g. Take out ice cream until fresh mix reaches the cylinder.	--
5. The mix in hopper is too cold.	a. The temperature is out of adjustment.	a. Reset the mix temperature L higher.	12
6. The mix in hopper is too warm.	a. The temperature is out of adjustment.	a. Reset the mix temperature L lower.	12
	b. The mix hopper cover is not in position.	b. Place the cover in position.	--
	c. The condenser is dirty.	c. Clean the condenser.	34
7. Excessive leakage in rear drip pan.	a. Missing or worn drive shaft seal on drive shaft.	a. Install or replace regularly.	19
	b. The rear shell bearing is worn.	b. Call service technician.	--
	c. Incorrect lubricant was used.	c. Use food grade lubricant.	--
	d. Inadequate lubricant of beater drive shaft.	d. Lubricate the beater drive shaft properly.	19
8. Excessive mix leakage from the bottom of the door spout	a. Incorrect lubricant was used.	a. Use food grade lubricant.	--
	b. Worn, missing or incorrect o-ring is on the draw valve.	b. Check the o-rings, Replace the O-rings every 3 months.	21
	c. Inadequate lubricant of draw valve.	c. Lubricate the draw valve properly.	21
9. Product is not feeding into the freezing cylinder.	a. Inadequate mix in the mix hopper.	a. Fill the mix hopper with mix.	23
	b. The mix inlet hole is frozen.	b. Contact service technician.	--
	c. The air pump is installed incorrectly.	c. Install air pump correctly.	18

10. The drive shaft is stuck in the drive coupling.	a. Rounded corners of drive shaft, coupling, or both.	a. Call service technician to correct cause, and to replace the necessary components. Do not lubricate the hex end of the drive shaft.	--
	b. Mix and lubricant collected in the drive coupling.	b. Brush clean the rear shell bearing area regularly.	32
11. The freezing cylinder walls are scored.	a. Broken pins on beater assembly.	a. Repair or replace the beater assembly. Be sure the scraper blades are properly seated on pins.	--
	b. The beater assembly is bent.	b. Repair or replace the beater assembly. Contact a service technician to correct the cause of insufficient mix in freezing cylinder.	--
	c. The front bearing is missing or worn on the dispensing door.	c. Install or replace the front bearing.	20
12. The unit goes out on overload excessively.	a. There are too many appliances plugged into the circuit.	a. A separate 20 Amp. circuit is needed for the machine to operate properly.	--
	b. An extension cord has been placed between the power cord and the wall receptacle.	b. If the extension cord is used, it must match the power cord in size of circuit ampacity.	--
	c. A lack of air circulation problems.	c. Contact a service technician.	--
13. Mix from one freezing cylinder bleeds over to the second cylinder.	a. The draw valve seal is worn, miss or is improperly lubricated.	a. Install and lubricate properly and replace seal every 3 months.	21

## Section 9

## Parts Replacement Schedule

Item	Part Number	Description	Qty.
M1	6378W000C02	Motor - Driven	2
M2	6378W600C11	Compressor – Main	2
M3	6378W600C03	Fan Motor - Main	1
M4	6378W600M11	Compressor – Mix	1
M5	6378W600M03	Fan Motor - Mix	1
M6	6378W600M13	Agitator Motor	1
LC	6378W000001	Thermostat of hopper	2
GT	6378W000002	Thermostat of evaporator	2
KM1	6378W000003	Contactora of Motor	2
KM2	6378W000003	Contactora of Compressor	2
T	6378WT7C201	Transformer	2
JR	6378WT7C203	Thermal Overload Relay	2
PC1	6378W702M11	Control Board	2
PC2	6378W702M12	Display Board	2
S2	6378W07C104	Indicator “Mix Low”	2
S1	6378W07C103	Switch - Draw	2
HPP1	6378W600C77	Pressure Switch – Main Compressor	2
HPP2	6378W600C76	Pressure Switch – Mix Compressor	1

