

Section1	To the installer	1
	Air Cooled Units	1
	Electrical Hook-Up Installation For 380 Volt/ 50Hertz/ 3 Phase, Supplied With Cord	1
	Specification	2
Section2	To the Operator	3
Section3	Safety	4
Section4	Installation Instructions	5
Section5	Important: Operating Control	7
	Power Keypad	8
	Wash Keypad	8
	Cool Keypad	8
	Mix Refrigeration Keypad	9
	Reset Keypad	9
	Standby Keypad	9
	Indicator Light-“Mix Low”	9
Section6	Operating Procedures	10
	Assembly	10
	Sanitizing	12
	Priming	12
	Closing procedure	13
	Draining product from the freezing cylinder	13
	Rinsing	13
	Cleaning	14
	Disassembly	14
	Brush cleaning	14
	Product hardness adjustment	16
Section7	Important: Operator Checklist	17
	During cleaning and sanitizing	17
	Troubleshooting Bacterial Count	17
	Regular Maintenance Checks	18
Section8	Troubleshooting Guide	19
Section9	Electrical Drawing	21

NOTE: Continuing research results in steady improvements; therefore, information in this manual is subject to change without notice.

Section1

To the installer

Air Cooled Units

The model 6348 ice cream machine's air cooling unit require a minimum of 15.2cm of clearance around both sides. Install the skirt provided on the right side of the unit and place the back of the unit against a wall to prevent recirculating of warm air.

Electrical Hook-Up Installation For 380 Volt/ 50Hertz/ 3 Phase, Supplied With Cord

This equipment is supplied with a 3-wire cord for connection to a single phase, 380 volt, 50 hertz, branch circuit supply. This unit must be plugged into a properly grounded receptacle. The cord provided for is 20 amp; therefore the wall outlet must also be 20 amp. Check the data label, located in the side panel, for electrical specifications.

If the supply cord is damaged, it must be replaced by the manufacturer, its service agent or similarly qualified person in order to avoid a hazard.

Permanent wiring may be employed if required by local codes. Instructions for conversion to permanent wiring are as follows:

1. Be sure the freezer is electrical disconnected.
2. Remove the appropriate panel and locate the small electrical box at the middle of the freezer.
3. Remove the factory-installed cord and strain relief bushing.
4. Route incoming permanent wiring through hole in base pan.
5. Connect two power supply leads. Attach ground (earth) wire to the grounding lug inside the electrical box.
6. Be sure the unit is properly grounded before applying power.

CAUTION: THIS EQUIPMENT MUST BE PROPERLY GROUNDED! FAILURE TO DO SO CAN RESULT IN SEVERE PERSONAL INJURY FROM ELECTRICAL SHOCK!

SPECIFICATIONS

MODEL 6348

FLOOR MODEL, GRAVITY FREEZER

DIMENSIONS:

Freezer: 55cm wide × 65cm deep × 138cm high

Packing: 66cm wide × 78cm deep × 155cm high

WEIGHT

Freezer: 204kg Packing: 219kg

L1 L2 L3
BROWN BLACK GREY N - BLUE

Section 1

To the installer

ELECTRICAL:

Voltage AC: 3 Phase 380-415V 50 Hertz

Total Run Amps: 20 Amps

Drive Motors: 1.0 HP×2

Main Compressor: 3650 BTU/Hr.×2

Mix Compressor: 480 BTU/Hr.

(BTU may vary depending on compressor used.)

Se 20 amp HACR circuit breaker

COOLING

Air-cooled required minimum 15.2cm air clearance around the freezer.

HOPPER

Two hoppers, 12.5 liters×2, refrigerated and insulated.

MACHINE VIEW

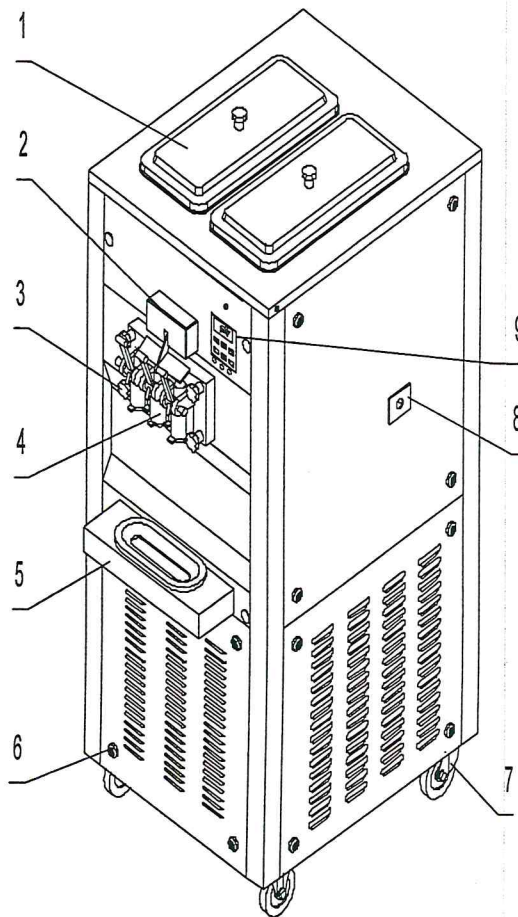

1. Top cover
2. Spigot switch cover
3. Dispensing door nut
4. Dispensing door
5. Drip pan
6. Panel attaching lock
7. Caster
8. Rear seal drip pan
9. Controls panel

Section 2

To the Operator

The freezer you have purchased has been carefully engineered and manufactured to give you dependable operation.

These units, when properly operated and cared for, will produce a consistent quality product. Like all mechanical products, they will require cleaning and maintenance. A minimum amount of care and attention is necessary if operating procedures outlined in this manual are followed closely.

This Operator's Manual should be read before operating or performing any maintenance on your equipment.

The Models 6348 will NOT eventually compensate and correct for any errors during the set-up or filling operations. Thus, the initial assembly and priming procedures are of extreme importance. It is strongly recommended that personnel responsible for the equipment's operation, both assembly and disassembly, go through these procedures together in order to be properly trained and to make sure that no misunderstandings exist.

MIX INFORMATION

The hygienic ice cream powder is required to be used for frozen production. Mix can vary considerably from one manufacturer to another. Differences in the type of ingredients, quality, and quantity all have a different bearing on the finished frozen product. A change in freezer performance that cannot be explained by a technical problem may be related to mix. Mix does not improve with age. Old mix or mix that has been stored at too high a temperature, can result in a finished product that is less than satisfactory from the appearance and taste standpoint.

Proper serving temperature varies from one manufacturer's mix to another. Most mixes should provide a satisfactory product in the -9°C to -5°C range. When checking the temperature, stir the thermometer in the frozen product to read the true temperature.

Always maintain at least 2cm of mix in the hopper. The maximum of mix in the hopper is 12liters in one hopper.

Section 3

Safety

We are concerned about the safety of the operator when he or she comes in contact with the freezer and its parts. We have gone to extreme efforts to design and manufacture built-in safety features to protect both you and service technician.

IMPORTANT- Failure to adhere to the following safety precautions may result in severe personal injury. Failure to comply with these warnings may damage will result in part replacement expense.

TO OPERATE SAFELY:

1. DO NOT operate the freezer without reading this operator's manual. Failure to follow this instruction may result in equipment damage, poor freezer performance, health hazards, or personal injury.
2. DO NOT operate the freezer unless it is properly grounded. Failure to follow this instruction may result in electrocution.
3. DO NOT allow untrained personnel to operate this machine. Failure to follow this instruction may result in severe personal injury to fingers or hands from hazardous moving parts.
4. DO NOT attempt any repairs unless the main power supply to the freezer has been disconnected. Failure to follow this instruction may result in electrocution. Contact your local authorized Distributor for service.
5. DO NOT operate the freezer with larger fuses than specified on the freezer data label. Failure to follow this instruction may result in electrocution or damage to the machine. Consult your electrician.
6. DO NOT operate the freezer unless all service panels and access doors are restrained with screws. Failure to follow this instruction may result in severe personal injury from hazardous moving parts.
7. DO NOT obstruct air intake and discharge openings:
minimum of 15.2cm of clearance around both sides. Install the skirt provided on the right side of the unit and place the back of the unit against a wall to prevent recirculating of warm air.

Failure to follow this instruction may cause poor freezer performance and damage to the machine.

1. DO NOT put objects or fingers in door spout. Failure to follow this instruction may result in contaminated product or personal injury from hazardous moving parts.
2. DO NOT remove the freezer door or beater assembly unless the control switches are in the "OFF" position. Failure to follow this instruction may result in severe personal injury from hazardous moving parts.

Section 4

Installation Instructions

Caution

Failure to install the freezer within recommended limits will result in poor performance of this system, premature component failure and cancellation of the warranty.

Installations of freezer involves moving the unit close to its permanent location, removing all protective packaging, setting in place and cleaning.

- A. Uncrate the freezer.
- B. Remove 4 nuts holding the freezer to the pedestal (Figure 4-1).
- C. Raise the freezer, then draw out the pedestal (Figure 4-2).

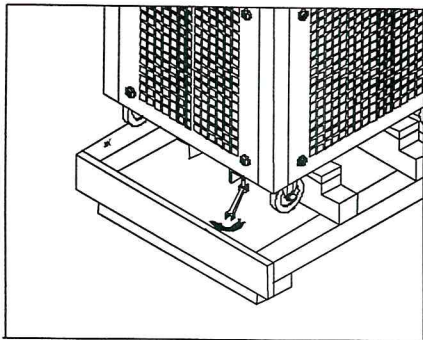

Figure 4-1

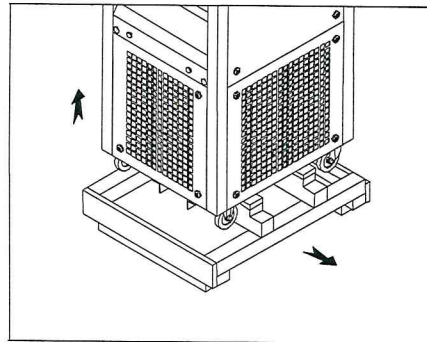

Figure 4-2

- D. The freezer required adequate ventilation. A minimum of 15.2cm of vent space is required for free flow of cooling air.
- E. Install the drip tray on the freezer (Figure 4-3).
- F. Install the beater with the beater seal (Figure 4-4).

Insert the beater assembly with beater seal through the rear shell bearing at the back of the cylinder evaporator and engage the hex end firmly into the female socket. When properly seated, the beater will not protrude beyond the front of the cylinder evaporator.

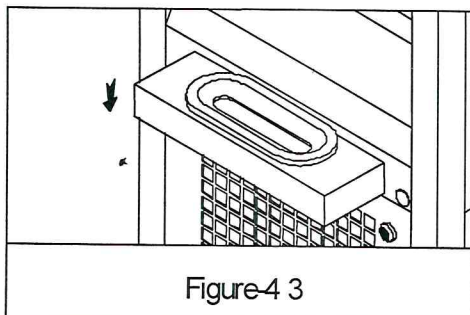

Figure 4-3

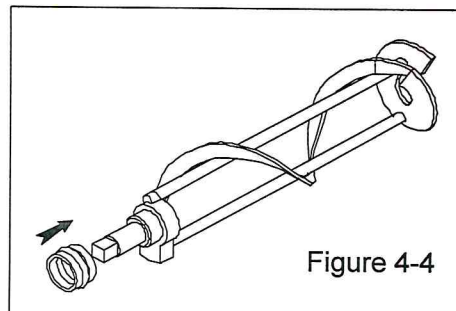
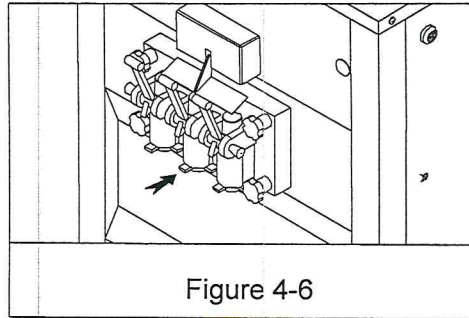
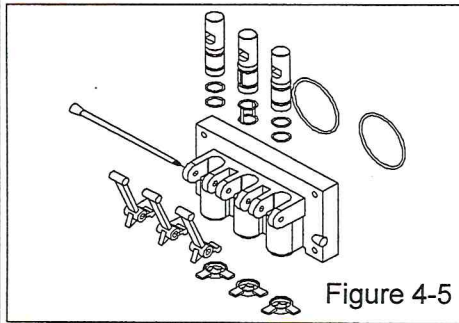

Figure 4-4

Section 4

Installation Instructions

G. Install the dispensing door on the freezer (Figure 4-5, 4-6).



H. Install the standpipe into the hopper (Figure 4-7, 4-8).

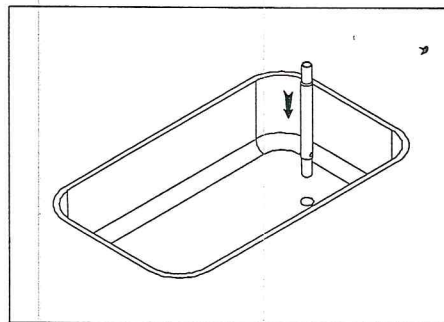
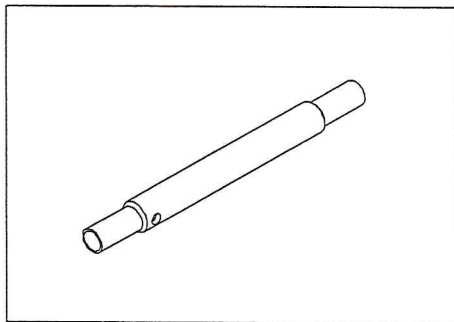

I. Connect the power cord. Check the nameplate on the freezer for supply. The unit must be connected to a properly grounded receptacle.

Caution

This Equipment Must Be Properly Grounded! Failure To Do So Can Result In Severe Personal Injury From Electrical Shock!

J. When connect the power supply, the fluorescent display indicate:

SPACEMAN MODEL 6348

K. Press STOP button, then press P button indicate temperature of cylinder and hopper. Figure 4-4

HOPPER	10C
CYLINDER	10C

Section 4

Installation Instructions

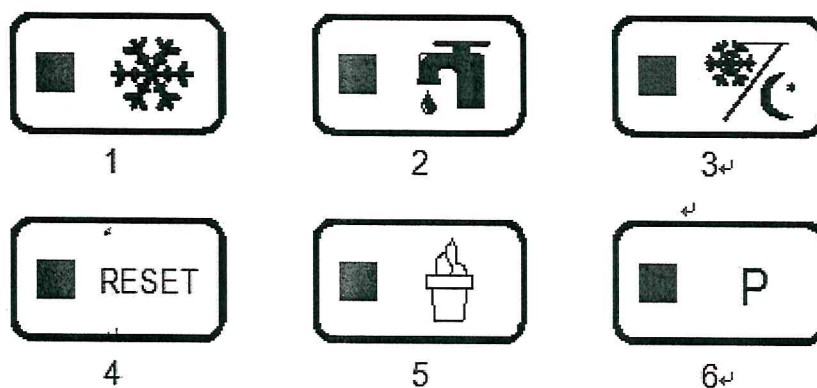

IMPORTANT: If one or both of two temperature value(s) indicate(s) "00C", you must STOP machine and contact the authorized service technician to check the temperature sensor connection.

PANEL REMOVAL:

To remove the panel, using a flat head screwdriver into the panel attaching lock.

Turn the lock in the direction shown in Figure 4-9.

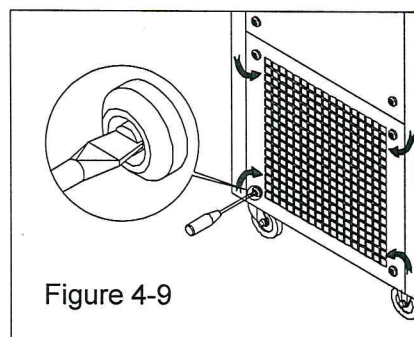

Before operating the freezer, it is required that the operator know the function of each operating control. Refer to Figure 5-1 Figure 5-2 for location of the controls panel of

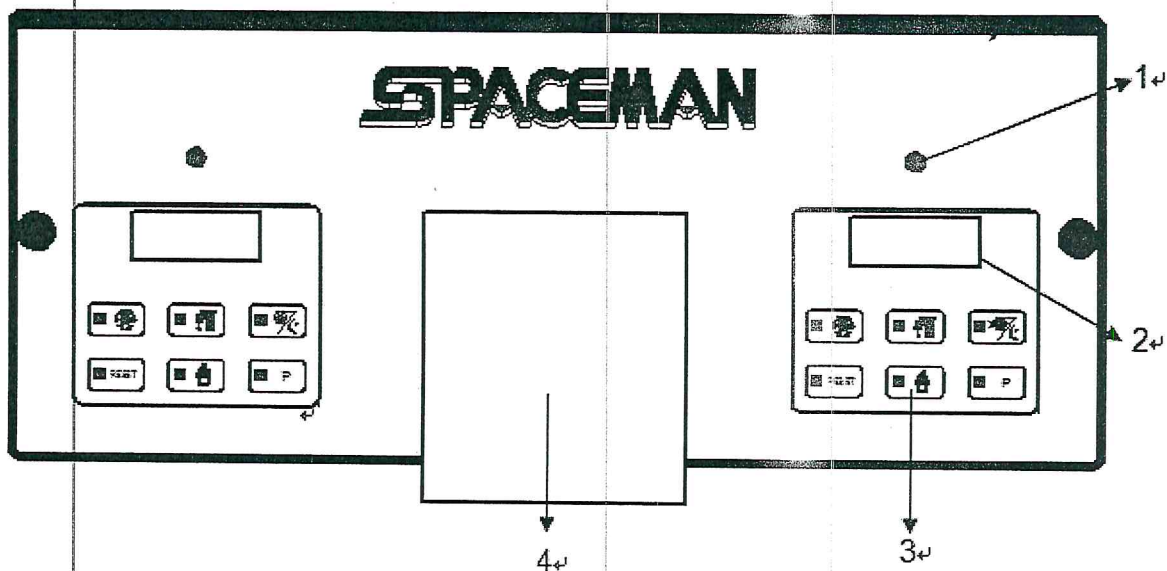

Item	Description
1	Indicator Led- "Mix Low"
2	Fluorescent Display
3	Touch Switch Panel
4	Spigot Switch Cover

Indicator Light-"Mix Low"

A mix level indicating light is located at the front of the machine. When the light is "ON", it indicates that the mix hopper has a low supply of mix and should be refilled as soon as possible. Always maintain at least 2cm of mix in the hopper. If you neglect to add mix, a freeze-up may occur. This will cause eventual damage to the beater assembly, the freezer door and gear box.

Fluorescent Display

During normal operation the display is used to indicate function, the temperature of the mix in the hopper and cylinder, the electric current of beater motor, error and warning messages.

Section 5

Important: Operating Control

Symbol Definitions

To better communicate in the International arena, symbols have replaced words on many of our operator switches. SPACEMAN equipment is designed with these International symbols. The following chart identifies the symbol definitions.

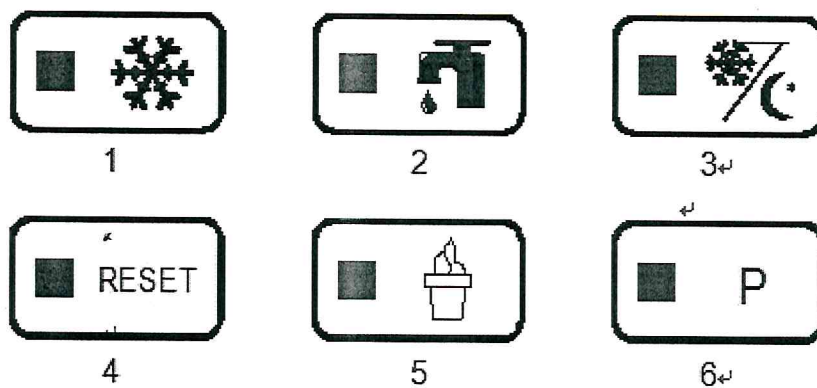

Figure 5-2

Item	Description
1	COOL Button and Led
2	WASH Button and Led
3	STANDBY Button and Led
4	RESET Button
5	ICE CREAM Button and Led
6	P Button

Operating Descriptions

When connect the power supply, the fluorescent display indicate:

SPACEMAN
MODEL 6348

RESET BUTTON (Item 4)

Press RESET button to exit current mode, fluorescent display indicates STOP.

Section 5

Important: Operating Control

It is possible to select any machine function. In order to change a function, IT IS ALWAYS NECESSARY to first press RESET button to return STOP.

WASH BUTTON (Item 2)

1. Press WASH button, the led of WASH comes "ON". The beater motor operate, fluorescent display indicates "WASHING".
2. Press P button, the fluorescent display indicates:

HOPPER	0.0C	→ Indicate present temperature of mix in hopper.
CYLINDER	0.0C	→ Indicate present temperature of mix in cylinder.

3. Press P button once again, the fluorescent display indicates:

CUR.	1.34 / 2.00A	→ Indicate the electric current of beater motor.
------	--------------	--

Number before "/" is present electric current of beater motor.

Number after "/" is maximum electric current of beater motor been set.

4. Press P button once again, fluorescent display indicates "WASHING". Press P button, fluorescent display will cycle from step 2.
5. Press Reset button, the led of WASH comes "OFF", fluorescent display indicates STOP. All function buttons are available.

COOL BUTTON (Item 1)

1. Press the COOL button, the led of COOL comes "ON". Fluorescent display indicates "COOLING". Beater motor and agitator operate, two refrigeration system is working. One for cylinder to make product, another for hopper to pre-cool mix and keep temperature of mix in hopper is under the default 5°C.
2. When temperature of mix in hopper is 1 degree lower than 4°C, mix hopper refrigeration system automatically stop and automatically start when 1 degree higher than 4°C. The default 4°C can be adjusted in SET MENU.
3. At the same time, refrigeration for cylinder is working until the unit cycles OFF, the product in the freezing cylinder will be at serving viscosity. Raise the draw valve, activating the beater motor, the product flowing from the door spout. The viscosity of product is controlled by electric current of beater motor. The higher electric current is higher viscosity of product. The viscosity can be adjusted in SET MENU.

Section 5

Important: Operating Control

4. Press P button, the fluorescent display indicates:

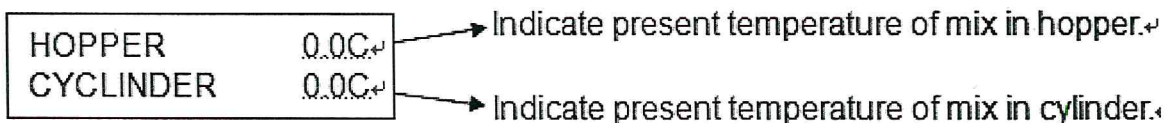

5. Press P button once again, the fluorescent display indicates:

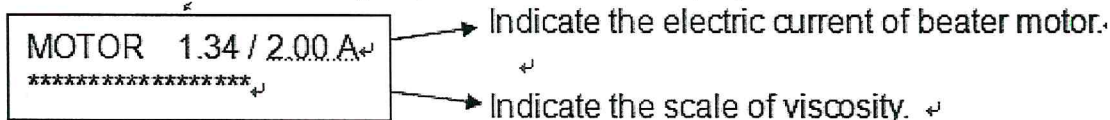

6. Press P button once again, fluorescent display indicates "COOLING". Press P button, fluorescent display will cycle from step 4.
7. Press Reset button, the led of COOL comes "OFF", fluorescent display indicates STOP. All function buttons are available.

STANDBY BUTTON (Item 3)

During long "No Sale" periods, the unit can be placed into the Standby mode. This maintains product temperatures below 5°C in both the hopper and the freezing cylinder, and helps prevent overheating and product breakdown. You will save significantly on energy consumption, as the compressor runs only for the time strictly necessary in order to keep product at its correct temperature.

1. Press STANDBY button, the led of STANDBY comes "ON". Fluorescent display indicates:

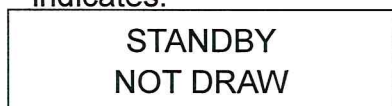

2. Press P button, fluorescent display indicates:

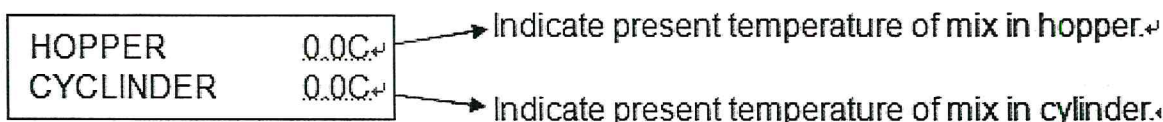

3. Indicate above menu for 5 seconds, fluorescent display will return to:



4. If no any button is pressed in 10 minutes, fluorescent display will enter save mode, led of background will OFF. Till press any button except Reset button, led of background will ON.
5. Press Reset button, the led of STANDBY comes "OFF", fluorescent display indicates STOP. All function buttons are available.

Section 5

Important: Operating Control

ICE CREAM BUTTON (Item 5)

1. Press ICE CREAM button, It is used to check the number of servings dispensed from the machine.

The fluorescent display indicates:

TODAY:	00000	→	Indicate the quantity of ice cream serviced today.
TOTAL:	0000000	→	Indicate the quantity of ice cream serviced total.

2. Indicate above menu for 5 seconds, fluorescent display will return to:

HOPPER	0.0C
CYLINDER	0.0C

3. Press Reset button, fluorescent display indicates STOP. All function buttons are available.

P BUTTON (Item 6)

1. At COOL and WASH mode, pressing P button will change the display menu between temperature and electrical current.
2. At STANDBY mode, pressing P button indicate temperature for 5 seconds.
3. At STOP mode, pressing P button indicate temperature.

SET MENU

The SET Menu is used to enter the parameter setting. To access the Menu, press and hold the RESET button for 3 seconds.

In the Menu program, the RESET, COOL, STANDBY, P, WASH and ICE CREAM button will function as menu keys.

- STANDBY BUTTON** - increases the value above the cursor.
- P BUTTON** - decreases the value above the cursor.
- RESET BUTTON** - change screen of setting.
- COOL BUTTON** - change item of setting.
- WASH BUTTON** - not save the setting and exit.
- ICE CREAM BUTTON** - save the setting and exit.

1. At STOP mode, press and hold the RESET button for 3 seconds, fluorescent display indicates:

VISCOSITY SET	
CURRENT:	2.00

Section 5

Important: Operating Control

- The above value is the maximum viscosity setting. When the electrical current achieves the value, the product is at serving viscosity, stop the refrigeration of cylinder. The higher electric current is higher viscosity of product.
 - Press the STANDBY button to increase the value.
 - Press the P button to decrease the value.
2. Press RESET button once, fluorescent display indicates:

MIX TEMPERATURE	
L	SET: 4.5C

- In COOL and STANDBY cycle, machine will start to cool mix in hopper when temperature of mix in hopper is 1 degree higher than above value. And stop it when the temperature is 1 degree lower. In the STANDBY cycle, same function for mix in cylinder.
 - Press the STANDBY button to increase the value.
 - Press the P button to decrease the value.
3. Press RESET button once, fluorescent display indicates:

2011 /01 /16
14 : 47 :58

- Set the date and time.
 - Press the STANDBY button to increase the value. Press the P button to decrease the value.
 - Press COOL button to set next parameter.
 - You must press ICE CREAM button for 3 second to save the adjustment.
4. Press RESET button once, fluorescent display indicates:

P: 0 00 : 00
P: 0 00 : 00

- Set the automatic program at set time.
- For example:
 - P: 1 08:00 start COOL mode at 08:00 every day.
 - P: 3 22:00 start STANDBY mode at 22:00 every day.
- Press the STANDBY button to increase the value. Press the P button to decrease the value.
- Press COOL button to set next parameter.

Section 5

Important: Operating Control

- P: 0 is no automatic program. There are 1 hour at least between COOL and other program.
 - You must press ICE CREAM button for 3 second to save the adjustment.
5. Press RESET button once, fluorescent display indicates:

ENTER CODE 0 0 0 0

- It is requirement of service set pass code
6. Press RESET button, fluorescent display will cycle from step 1.
7. If exit SET MENU not save setting, press WASH button, fluorescent display indicates:

STOP NOT SAVE

8. fluorescent display indicates:

STOP SAVE OK

9. Press Reset button, fluorescent display indicates STOP. All function buttons are available.

FAULT DESCRIPTION

Listed below are the variable fault messages which will appear, along with an explanation for the corrective action.

If the machine has been stopped a long time due to a failure, it is necessary that you check product temperature before starting the sale again; if the temperature is over +6°C, the machine must be emptied, cleaned and sanitized, and filled up with new fresh mix.

1. In the course of any mode, press P button indicate temperature of cylinder and hopper.

IMPORTANT: If one or both of two temperature value(s) indicate(s) "00C" without any change for more 2 minutes, you must STOP machine and contact the authorized service technician to check the temperature sensor.

HOPPER	0.0C
CYCLINDER	0.0C

Section 5

Important: Operating Control

2. In COOLING cycle, if fluorescent display appears:

<p style="text-align: center;">STOP 1 LOW TEM. PROTECT</p>
--

The temperature of cylinder achieves or lower than the lowest temperature setting. The led of COOL and STANDBY will be sparked, compressor stop, beater motor working.

Press RESET button, fluorescent display indicates STOP.

Lower viscosity setting in SET MENU item1 or contact the authorized service technician to check lower the temperature of cylinder protection setting

Press the WASH button and observe the machine's performance.

If the beater motor is turning properly, press the RESET button.

Press COOL button to resume normal operation.

If no any button is pressed in 10 minutes, machine will enter STANDBY mode automatically.

3. In COOLING cycle, if fluorescent display appears:

<p style="text-align: center;">STOP 2 MOTOR * OVERLOAD</p>
--

The electrical current of beater motor achieves or more than highest current setting, the led of COOL will be sparked, machine stop.

Press RESET button, fluorescent display indicates STOP.

Lower viscosity setting in SET MENU item1 or contact the authorized service technician to check highest current setting.

Press the WASH button and observe the machine's performance.

If the beater motor is turning properly, press the RESET button.

Press other button to resume normal operation.

4. In COOLING cycle, if fluorescent display appears:

<p style="text-align: center;">LOW MIX ADD MIX</p>
--

The led of Mix Low will be sparked, it indicates that the mix hopper has a low supply of mix and should be refilled as soon as possible.

Otherwise machine stop refrigeration of cylinder after Low mix delay. The time of Low mix delay will be setting by service technician.

When you add enough mix, the led of Mix Low OFF, machine will enter COOL cycle automatically.

5. Reset Button

The reset protects the beater motor from an overload condition. If an overload occurs, the reset mechanism will trip. The machine shuts down, it appears no

Section 5

Important: Operating Control

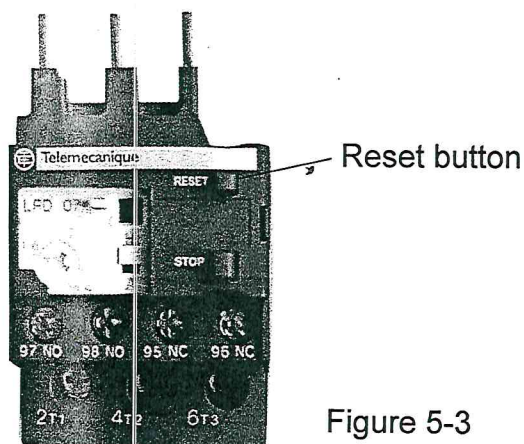

Figure 5-3

WARNING:

Do not use metal objects to press the reset button. Failure to comply may result in severe personal injury or death.

Press the WASH button and observe the machine's performance. If the beater motor is turning properly, press the RESET button to cancel the cycle. Press other button to resume normal operation. If the machine shuts down again, contact your authorized service technician.

6. PRESSURE SWITCH

It protects the refrigeration system and causes the compressor to stop if the pressure of the system exceeds the pressure switch setting value. This may occur especially due to a lack of air circulation problems. The switch resets itself manually.

WARNING:

If the compressor runs for an excessive time or stops and starts repeatedly, this indicates insufficient condensation; check the causes and contact authorized service technician.

Section 6

Operating Procedures

The machine has been selected to illustrate the pictured step-by-step operating procedures. It has a 1.7 liter capacity in freezing cylinder. The mix flows by gravity from the hopper to the freezing cylinder through an air tube.

We begin our instructions at the point where we enter the store in the morning and find the parts disassembled and laid out to air dry from the previous night's cleaning.

These opening procedures will show you how to assemble these parts into the freezer with fresh mix in preparation to serve your first portion.

Only there is raw material in the mix hopper can you run the machine "Cool". You should STOP the machine if there is no raw material in the hopper.

There are close relations between hardness setting up and environment temperature producing the finished product actually.

Assembly

Note: When lubrication parts, use an approved food grade lubricant.

Step 1

Install the beater assembly.

Slide the beater o-ring into the flange on the drive shaft of the beater assembly.

DO NOT LUBRICATE THE HEX END.

Insert the beater assembly through the rear shell bearing at the back of the freezing cylinder and engage the hex end firmly into the female socket. When properly seated, the beater will not protrude beyond the front of the freezing cylinder. Beater rotation must be clockwise as viewed looking into the freezing cylinder.

Step 2

1. Assemble the freezer door. Place the large o-ring into the grooves on the back of the freezer door and lubricate with lubricant.
2. Assemble the dispensing valve. Slide the O-rings and O-O ring into the grooves on the draw valve and lubricate with lubricant.
3. Assemble the dispensing handle with dispensing handle retention. Insert the dispensing handle through the slotted opening in the dispensing valve and align the other end with the cross holes of the dispensing door.

Hint: The dispensing handle may be aligned with left or right cross hole. The dispensing valve handle will be placed through the opposite cross hole of the dispensing handle.

Insert the dispensing valve handle through the opposite cross hole and into the opening of the dispensing handle.

Hint: The dispensing valve handle can be assembled at varied vertical positions. Choose an angle which is comfortable for you. The dispensing valve must be raised completely when the dispensing valve handle is down.

Section 6

Operating Procedures

4. Assemble three design caps to the bottom of the dispensing door spout.

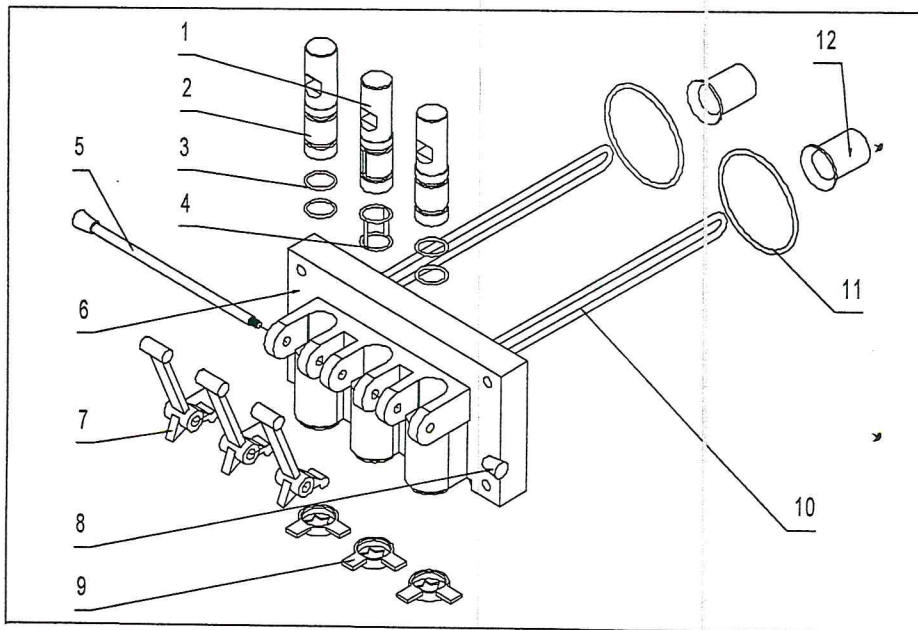

ITEM	Part Number	QTY.	Description
1	6348206007	1	Middle Dispensing Valve
2	6348206004	2	Side Dispensing Valve
3	6348206006	4	O-ring
4	6348206002	1	O-O ring
5	6348206005	1	Dispensing Handle Retention
6	6348206001	1	Dispensing door
7	6348206008	3	Dispensing Handle
8	6348206009	2	Screw cap
9	6348206003	3	Design Cap
10	6348206031	2	Beat Pole
11	6348020601	2	Seal of Dispensing Door
12	6348206032	2	Bearing Front

Step 3

Install the freezer door. Insert the hand screws into the slots in the freezer door. With both hands, hold the sides of the beater assembly. Finger-tighten the hand screws equally drive shafts. Finger-tighten the hand screws equally to insure that the door is snug. Don't over-tighten.

Section 6

Operating Procedures

Sanitizing

Step 1

Prepare 3.8 liters of an approved 100PPM sanitizing solution. **USE WARM WATER AND FOLLOW THE MANUFACTURER'S SPECIFICATIONS.**

Step 2

Pour 3.8 liters of sanitizing solution into the hopper and allow it to flow into the freezing cylinder.

Step 3

While the solution is flowing into the freezing cylinder, brush-clean the mix hopper, mix level stem, mix inlet hole, and air tube.

Step 4

Press the Wash Keypad. This will cause the sanitizing solution in the freezing cylinder to be agitated. Allow it to agitate for five minutes.

Step 5

Place an empty pail beneath the door spout and raise the draw valve. Draw off all of the sanitizing solution. When the sanitizer stops flowing from the door spout, lower the draw valve and place the power switch in the "OFF" position.

Step 6

With sanitized hands, stand the air tube in the corner of the mix hopper.

Step 7

Place the agitator on the agitator drive shaft housing.
Figure 6-20

Note: If agitator should stop turning during normal operation, with sanitized hands, remove agitator from agitator drive shaft housing and brush clean with sanitizing solution. Install the agitator back onto the agitator drive shaft housing.

Step 8

Repeat Steps 1 through 6 for the second freezing cylinder.

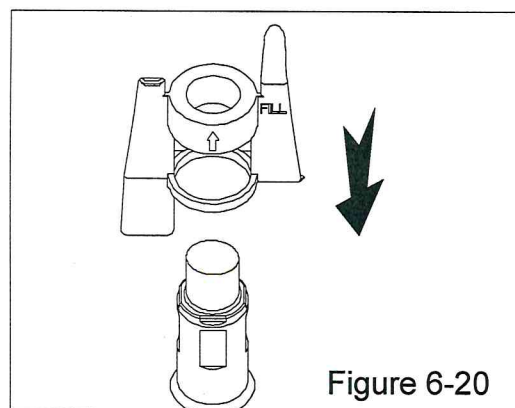

Priming

Prime the machine as close as possible to the time of first product draw.

Never: 1. Too much water in the mix.

2. Press Cool Button when only water in the hoppers and evaporators.

3. Press Cool Button when no mix or in the hoppers.

Step 1

Install the air tube in the mix inlet hole.

Step 2

Install the front drip tray and splash shield under the freezer door.

Steps 3

Slide the rear drip into the hole in the side panel.

Step 4

With a pail beneath the door spout, raise the draw valve. Fill the mix hopper with FRESH mix and allow it to flow into the freezing cylinder. This will force out any remaining sanitizing solution. When full strength mix is flowing from the door spout, lower the draw valve.

Note: Use only fresh mix when priming the freeze.

Section 6

Operating Procedures

Step 5

Place the mix hopper cover in position.

Step 6

Pressing the Cool Keypad. When the unit cycles off, the product will be ready to serve.

Closing procedure

To disassemble this machine, the following items will be needed:

- Two cleaning pails
- Sanitized stainless steel rerun can with lid
- Necessary brushes
- Cleaner
- Single service towels

Draining product from the freezing cylinder

Step 1

Pressing the Cool Keypad in the "OFF" position as far ahead of cleaning time as possible. This will allow frozen product to soften for easier cleaning.

Step 2

Lift the hopper cover. Remove the air tube and mix level float. Take them to the sink for cleaning.

Step 3

With a sanitized pail beneath the door spout, pressing the Wash Keypad in "On" position and raise the draw valve. When all the product stops flowing from the door spout, lower the draw valve and press the Wash Keypad in the "OFF" position. If local health codes permit, empty the rerun into a sanitized stainless steel rerun can. Cover the container and place it in the walk-in cooler.

Rinsing

Step 1

Pour one 3.8 liters of cool, clean water into the mix hopper. With the brushes, scrub the mix hopper, the mix level stem and the mix inlet hole.

Step 2

With a pail beneath the door spout, press the Wash Keypad in "On" position and raise the draw valve. Drain all the rinse water stops flowing from the freezing cylinder. When the rinse water stops flowing from the door spout, lower the draw valve and press the Wash Keypad in the "OFF" position.

Repeat this procedure until the rinse water being drawn from the freezing cylinder is clear.

Section 6

Operating Procedures

Cleaning

Step 1

Prepare 3.8 liters of an approved cleaning solution. **USE WARM WATER AND FOLLOW THE MANUFACTURE'S SPECIFICATIONS..**

Step 2

Pour the 3.8 liters of cleaning solution to the mix hopper and allow it to flow into the flow into the freezing cylinder.

Step 3

While the solution is following into the freezing cylinder, brush-clean the mix hopper, mix level stem and mix inlet hole.

Step 4

Press the Wash Keypad in "On" position. This will cause the cleaning solution in the freezing cylinder to agitate.

Step 5

Place an empty pail beneath the door spout and raise the draw valve. Draw off all the cleaning solution.

When the solution stops flowing from the door spout, lower the draw valve and press the Wash Keypad in the "OFF" position.

Disassembly

Step 1

BE SURE THE POWER SUPPLY IS DISCONNECTED TO ELIMINATE THE CHANCE OF MOVING PARTS. CHECK TO MAKE SURE NO LEDS ARE LIT ON

THE CONTROL PANEL AND FLUORESCENT DISPLAY.

Step 2

Remove the hand screws and the dispensing door. Remove the beater assembly from the freezing cylinders and take these parts to the sink for cleaning.

Step 3

Remove the front drip tray and the splash shield from the freezer. Take them to the sink for cleaning.

Section 6

Operating Procedures

Brush cleaning

Step 1. Prepare a sink with an approved cleaning solution. USE WARM WATER AND FOLLOW THE MANUFACTURER'S SPECIFICATIONS.

IMPORTANT: Follow label directions, as too STRONG of a solution can cause parts damage, while too MILD of a solution will not provide adequate cleaning. Make sure all brushes are available for brush cleaning.

Step 2

Remove the O-rings from the drive shaft of the beater assembly.

Note: To remove the O-ring, use a single service towel to grasp the O-ring. Apply pressure in an upward direction until the O-ring pops out of its groove. With the other hand, push the top of the O-ring forward, and it will roll out of the groove and can be easily removed. If there is more than one O-ring to be removed, always remove the rear O-ring first. This will allow the O-ring to slide over the forward rings without falling into the open grooves.

Step 3

From the freezer door, remove the design cap, draw valve handle, valve lifter arm, and draw valve. Remove all O-rings.

Step 4

Remove the large O-rings and front bearing from the back of the freezer door.

Step 5

Return to the freezer with a small amount of cleaning solution. With the black bristle brush, brush clean the rear shell bearing at the back of the freezing cylinder.

Step 6

Remove the rear drip pan from the side panel and take it to the sink for cleaning.

Note: If the drip pan is filled with an excessive amount of mix, this is an indication that the drive shaft O-ring of the beater assembly should be replaced or properly lubricated.

Step 7

Thoroughly brush clean all disassembled parts in the cleaning solution. Make sure all lubricant and mix film is removed. Take particular care to brush clean the draw valve core in the freezer door. Place all the cleaned parts on a clean, dry surface to air dry overnight.

Step 8

Wipe clean all exterior surfaces of the freezer.

Section 7

Important: Operating Checklist

During cleaning and sanitizing

Cleaning and sanitizing schedules are governed by your State or local regulatory agencies and must be followed accordingly. The following check points should be stressed during the cleaning and sanitizing operations.

WE RECOMMEND DAILY CLEANING AND SANITIZING.

Troubleshooting Bacterial Count

1. Thoroughly clean and sanitize the machine regularly, including complete disassembly and brush cleaning.
2. Use all brushes for thorough cleaning. The brushes are specially designed to reach all mix passageways.
3. Use the smaller, white bristle brush to clean the mix inlet hole which extends from the mix hopper down to the rear of the freezing cylinder.
4. Use the black bristle brush to thoroughly clean the rear of the freezing cylinder. Be sure to have a generous amount of cleaning solution on the brush.
5. IF LOCAL HEALTH CODES PERMIT THE USE OF RERUN, make sure the mix rerun is stored in a sanitized, covered stainless steel container and is used the following day. DO NOT prime the machine with rerun. When using rerun, skim off the foam and discard. Mix the rerun with fresh mix in a ratio of 50/50 during the day's operation.

6. On a designated day of the week, run the mix as low as feasible and discard after closing. This will break the rerun cycle and reduce the possibility of high bacteria and coliform counts.
7. Properly prepare the cleaning and sanitizing solutions. Read and follow label directions carefully. Too strong of a solution may damage the parts and too weak of a solution will not do an adequate job of cleaning or sanitizing.
8. The temperature of the mix in the mix hopper and walk-in cooler should be below 7 °C.

Section 7

Important: Operating Checklist

9. If the drive motor is protected as overload or high temperature, please assure the reason of protection at first. When solve a problem, then press the reset button (blue color button) in the thermal overload relay shown in Figure 7-1. The thermal overload relays are located sides of mix compressor.

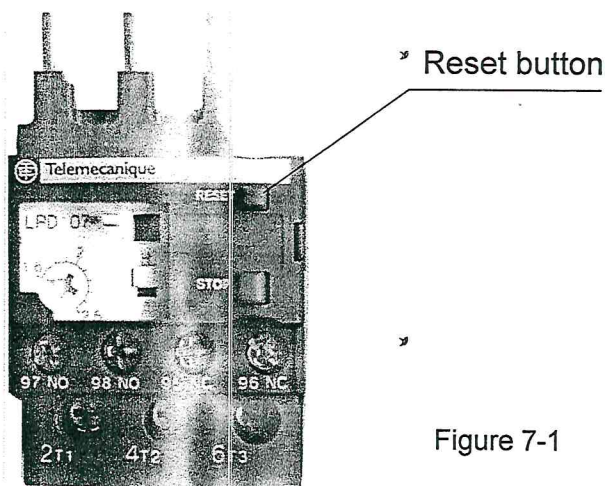

Figure 7-1

Regular Maintenance Checks

7. Check the rear shell bearing for signs of wear (excessive mix leakage in rear drip pan) and be certain it is properly cleaned.
8. Using a screwdriver and cloth towel, keep the rear shell bearing and the female hex drive socket clean and free of lubricant and mix deposits.
9. Dispose of O-rings or seals if they are worn, torn, or fit too loosely, and replace with new ones.
10. If an overload condition occurs frequently, maybe the belt is worn, torn, or fit too loosely. Dispose of the belt and replace with new ones.
11. Follow all lubricating procedures as outlined in ASSEMBLY.
12. This machine is air cooled, check the condenser for an accumulation of dirt and lint. A dirty condenser will reduce the efficiency and capacity of the machine. Condensers should be cleaned monthly with a soft brush. Never use

screwdrivers or other metal probes to clean between the fins. Failure to comply may result in electrocution.

13. This machine is equipped with an auxiliary refrigeration system, check the auxiliary condenser will reduce the refrigeration capacity of the mix hopper. Condensers must be cleaned monthly with a soft brush. Never use screwdrivers or other metal probes to clean between the fins. Failure to comply may result in electrocution.

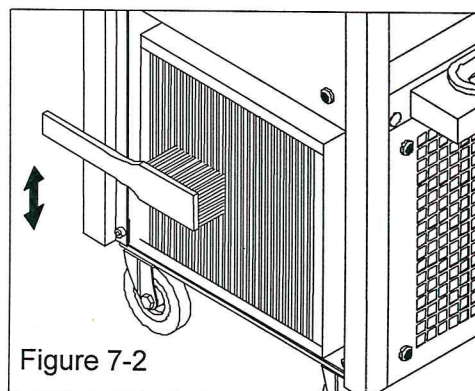

Figure 7-2

Section 8

Troubleshooting Guide

PROBLEM	PROBABLE CAUSE	REMEDY	PAGE REF.
1. No product being dispensed	a. The Power Keypad is in the "OFF" position.	a. Press the Power keypad in the "ON" position	8
	b. The mix level is inadequate in the mix hopper.	b. Fill the mix hopper with mix.	
	c. The beater motor overload.	c. Reset the freezer.	9
	d. The unit is unplugged at the wall receptacle.	d. Plug in the power cord. Press the reset keypad.	1 9
	e. The circuit breaker is tripped or the fuse is blown.	e. Place the circuit breaker in the "ON" position, or replace the fuse. Press the reset keypad.	1 9
	f. The freezer door is incorrectly assembly.	f. See "Operating Procedures" for proper installation.	10
	g. Product is being drawn off in excess of freezer's capacity.	g. Stop drawing product and allow the unit to recover.	13
2. The machine will not operate in the "AUTO" mode.	a. The unit is unplugged.	a. Plug in the power cord; press the reset keypad.	1
	b. The circuit breaker is tripped or the fuse is blown.	b. Place the circuit breaker in the "ON" position, or replace the fuse. Press the reset	1 9

		c. The beater motor overload, causing a loss of power to the power switch.	keypad. c. Reset the freezer.	9
3.	The product is too hard	a. The 6-position switch is set too hard.	a. Adjust the 6-position switch roller.	16
4.	The product is too soft	a. The 6-position switch is set too soft.	a. Adjust the 6-position switch roller.	16

Section 8

Troubleshooting Guide

PROBLEM	PROBABLE CAUSE	REMEDY	PAGE REF.
5. The freezing cylinder walls are scored.	a. Operating freezer without the front bearing on the freezer door. b. The gear unit or the direct drive is out of alignment.	a. Install the front bearing on the freezer door. b. Contact service technician.	10
6. Excessive leakage in rear drip pan.	a. A worn or defective O-ring are on the beater drive shaft. b. The rear shell bearing is worn. c. Incorrect lubricant was used. d. Inadequate lubricant of beater drive shaft.	a. Replace the O-rings every 3 months. b. Contact service technician. c. Use food lubricant. d. Lubricate the beater drive shaft properly.	10
7. The draw valve is leaking.	a. Incorrect lubricant was used. b. A worn or defective O-ring are on the draw valve. c. Inadequate lubricant of draw valve.	a. Use food lubricant. b. Replace the O-rings every 3 months. c. Lubricate the draw valve shaft properly.	
8. Product is not feeding into	a. The mix level is inadequate in the mix hopper.	a. Fill the mix hopper with mix.	13

the freezing cylinder.	b. The mix inlet hole is frozen	b. Contact service technician.	
9. The unit goes out on overload excessively.	a. There are too many appliances plugged into the circuit.	a. A separate 15 Amp. circuit is needed for the freezer to operate properly.	1
	b. An extension cord has been placed between the power cord and the wall receptacle.	b. If the extension cord is used, it must match the power cord in size of circuit ampacity.	1

Section9

Electrical Drawing

ITEM	Part Number	QTY.	Description
M1	6348600C03	2	Drive Motor
M2	6348600C01	2	Main Compressor
M3	6348600C03	1	Main Fan Motor
M4	6348600M11	1	Mix Compressor
M5	6348600M12	1	Mix Fan Motor
KM1	6348600002	2	Contact of Motor
KM2	6348600001	2	Contact of Compressor
T1	6348T7C201	2	Transformer
T2	6348T7C202	2	Inductance
JR	6348T7C203	2	Thermal Overload Relay
S1~S6	6348T7C204	2	Keypad
PC1	6348T7M01	2	Control Board
PC2	6348T7M02	2	Indicator Board
L6	6348T7C203	2	Indicator Light- "Mix Low"
S8	6348T7C103	2	Spigot Switch

